



US011262134B1

(12) **United States Patent**
Tucker et al.

(10) **Patent No.:** **US 11,262,134 B1**
(45) **Date of Patent:** **Mar. 1, 2022**

(54) **ADVANCED COOLING SYSTEM USING THROTTLED INTERNAL COOLING PASSAGE FLOW FOR A WINDOW ASSEMBLY, AND METHODS OF FABRICATION AND USE THEREOF**

(56) **References Cited**

U.S. PATENT DOCUMENTS

4,949,920 A 8/1990 Schindel et al.
4,978,577 A 12/1990 Furohit et al.
(Continued)

(71) Applicant: **Mainstream Engineering Corporation**, Rockledge, FL (US)

OTHER PUBLICATIONS

(72) Inventors: **Brian P. Tucker**, Orlando, FL (US);
Joshua D. Sole, Rockledge, FL (US);
Justin J. Hill, Merritt Island, FL (US);
Robert P. Scaringe, Rockledge, FL (US)

Harris "Development of hot-pressed chemical-vapor-deposited zinc sulfide and zinc selenide in the United States for optical windows" Proc. of SPIE vol. 6545 2007, p. 654502-1-654502-27 (Year: 2007).*

(Continued)

(73) Assignee: **Mainstream Engineering Corporation**, Rockledge, FL (US)

Primary Examiner — David P Porta
Assistant Examiner — Mamadou Faye
(74) *Attorney, Agent, or Firm* — Michael W. O'Neill, Esq.

(*) Notice: Subject to any disclaimer, the term of this patent is extended or adjusted under 35 U.S.C. 154(b) by 0 days.

(21) Appl. No.: **17/187,972**

(57) **ABSTRACT**

(22) Filed: **Mar. 1, 2021**

A window assembly heat transfer system is disclosed in which a window member has a selected transparency to monitored or sensed light wavelengths. One or more passages are provided in the window member for flowing a single-phase or two-phase heat transfer fluid, the passages being optically non-transparent to the monitored or sensed light wavelengths. A mechanism allows either evaporation or condensation of the fluid and/or balancing of a flow of the fluid within the passages. In one embodiment, the window assembly can be made by producing passages in a top surface of a first single plate, optionally producing passages in a bottom surface of a second single plate and bonding the top surface of the first plate to a bottom surface of a second single plate to form the window member with the passage or passages. In another embodiment, the window assembly can be made by providing a core around which the window member material is grown and thereafter removing the core to produce the passage or passages.

Related U.S. Application Data

(63) Continuation of application No. 16/745,966, filed on Jan. 17, 2020, now Pat. No. 11,015,874, which is a (Continued)

(51) **Int. Cl.**
G01J 5/08 (2006.01)
F28D 15/00 (2006.01)
(Continued)

(52) **U.S. Cl.**
CPC **F28D 15/00** (2013.01); **C23C 16/305** (2013.01); **C23C 16/56** (2013.01); **C30B 25/02** (2013.01);
(Continued)

(58) **Field of Classification Search**
None
See application file for complete search history.

13 Claims, 10 Drawing Sheets

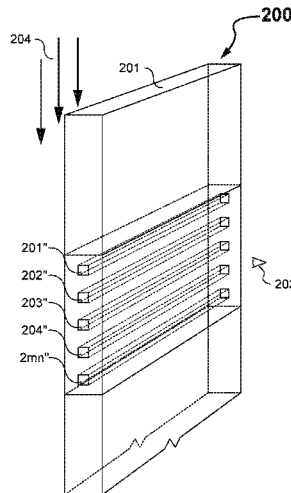

Related U.S. Application Data

continuation of application No. 15/478,474, filed on Apr. 4, 2017, now Pat. No. 10,591,221.

6,134,785	A	10/2000	Walter
6,530,539	B2	3/2003	Goldman et al.
6,943,336	B2	9/2005	Mangoubi
8,575,527	B2	11/2013	Fry
8,803,088	B1	8/2014	Ravichandran et al.
8,933,860	B2*	1/2015	Schlie F28D 15/0266 343/872

(51) **Int. Cl.**

<i>C23C 16/56</i>	(2006.01)
<i>C30B 25/02</i>	(2006.01)
<i>C30B 33/08</i>	(2006.01)
<i>C30B 29/48</i>	(2006.01)
<i>C23C 16/30</i>	(2006.01)
<i>B64C 1/14</i>	(2006.01)
<i>F28D 21/00</i>	(2006.01)
<i>F42B 15/34</i>	(2006.01)

2008/0012499	A1	1/2008	Ragay
2010/0206523	A1	8/2010	Chen et al.
2012/0111992	A1	5/2012	Fry
2013/0306989	A1	11/2013	Kub
2015/0354907	A1	12/2015	Hertzberg
2015/0358558	A1	12/2015	McKenzie
2017/0211415	A1	7/2017	Swift

OTHER PUBLICATIONS

(52) **U.S. Cl.**

CPC *C30B 29/48* (2013.01); *C30B 33/08* (2013.01); *B64C 1/1484* (2013.01); *F28D 2021/0021* (2013.01); *F42B 15/34* (2013.01)

Wojciechowski, et al., Internally Cooled Window for Endoatmospheric Homing, AIAA, May 1992.
 Wojciechowski, et al., Internally Cooled Window for Endoatmospheric Homing, AIAA, Jun. 1993.
 Burzlaff, et al., Active Two-Phase Cooling of an IR Window for a Hypersonic Interceptor, AIAA, Jun. 1993.
 Pitschman, et al., Reaction Bonded Silicon Carbide Material Characteristics as Related to Its Use in High Power Laser Systems, Proc. SPIE 9193, Novel Optical Systems Design and Optimization XVII, 919312 (Sep. 12, 2014).
 II-VI Incorporated, Reaction Bonded SiC, www.iiviinfrared.com/Optical-Materials/reaction-bonded-SiC.html, accessed Oct. 30, 2019.

(56)

References Cited

U.S. PATENT DOCUMENTS

5,025,856	A	6/1991	VanDyke
5,073,831	A	12/1991	Flint
5,075,797	A	12/1991	Jones
5,145,716	A	9/1992	Paserin
5,291,830	A	3/1994	Zwan
5,403,783	A	4/1995	Nakanishi

* cited by examiner

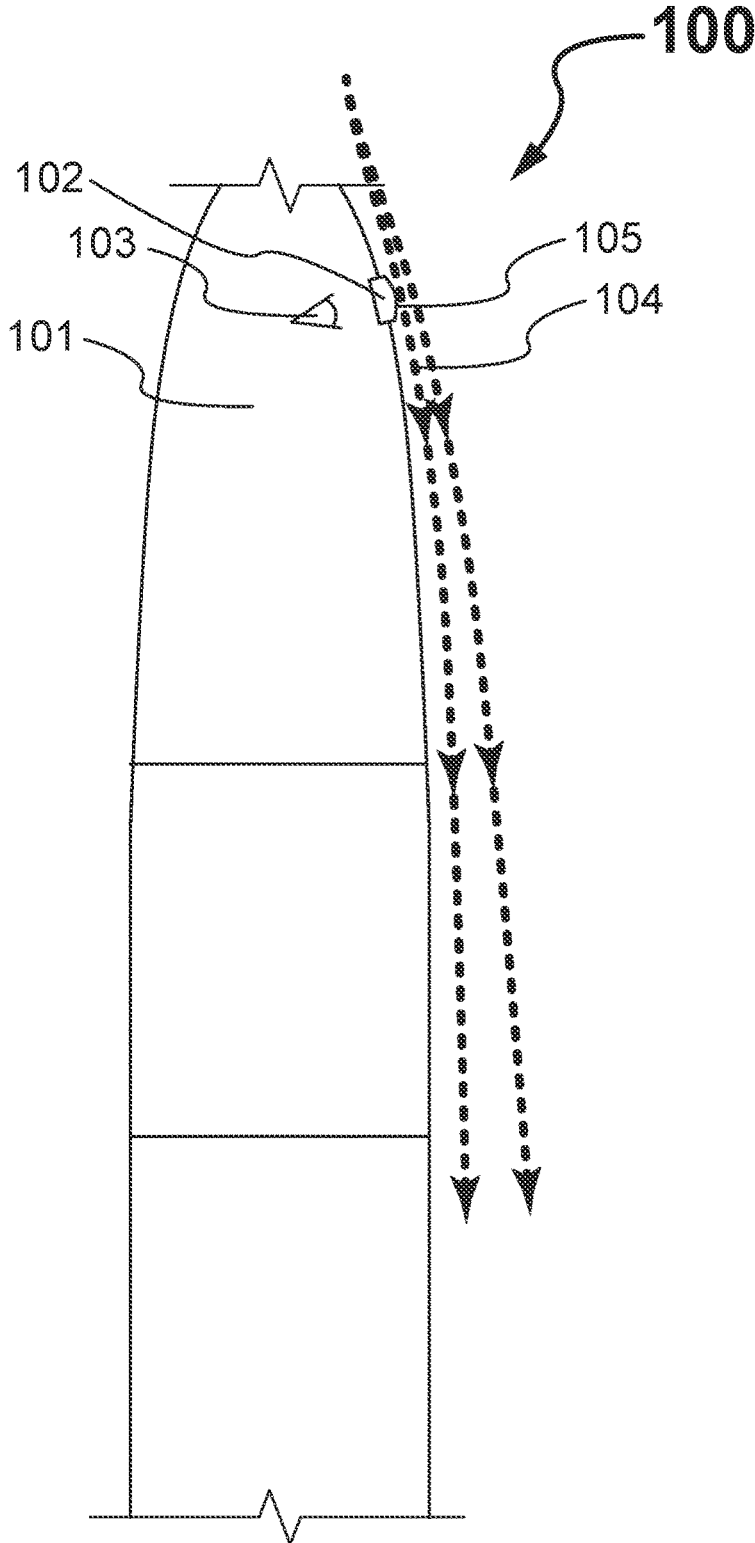

Figure 1 Prior Art

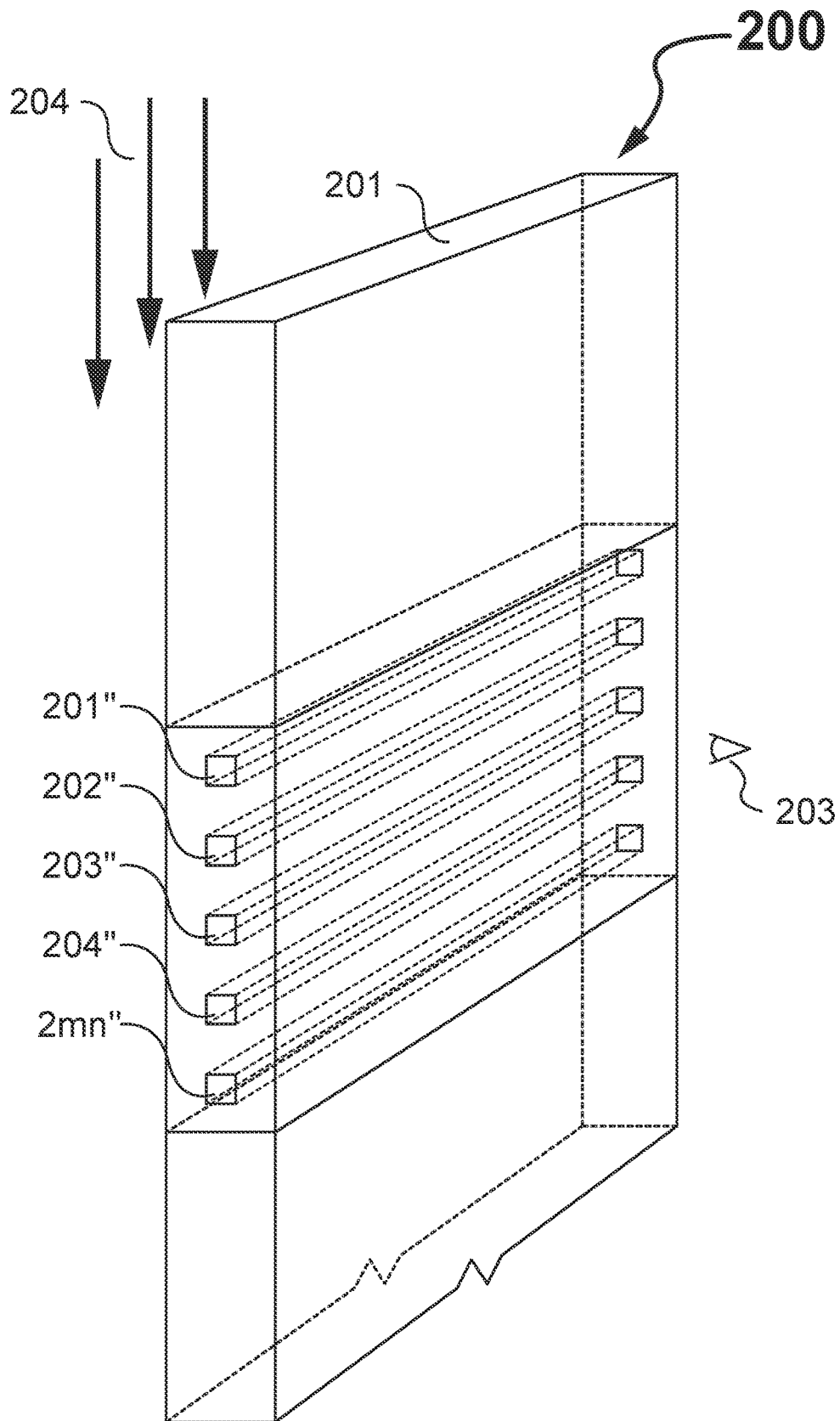

Figure 2a

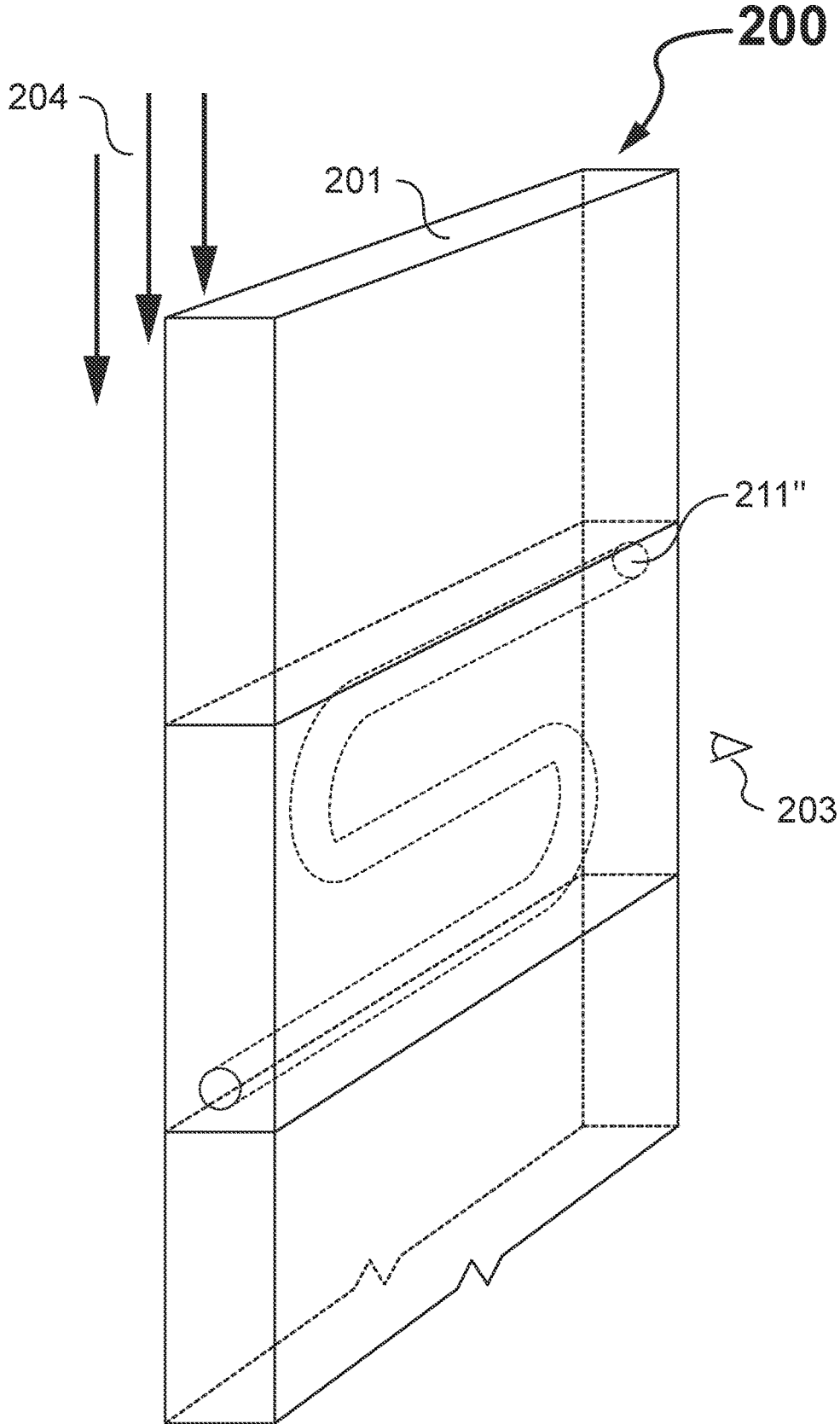

Figure 2b

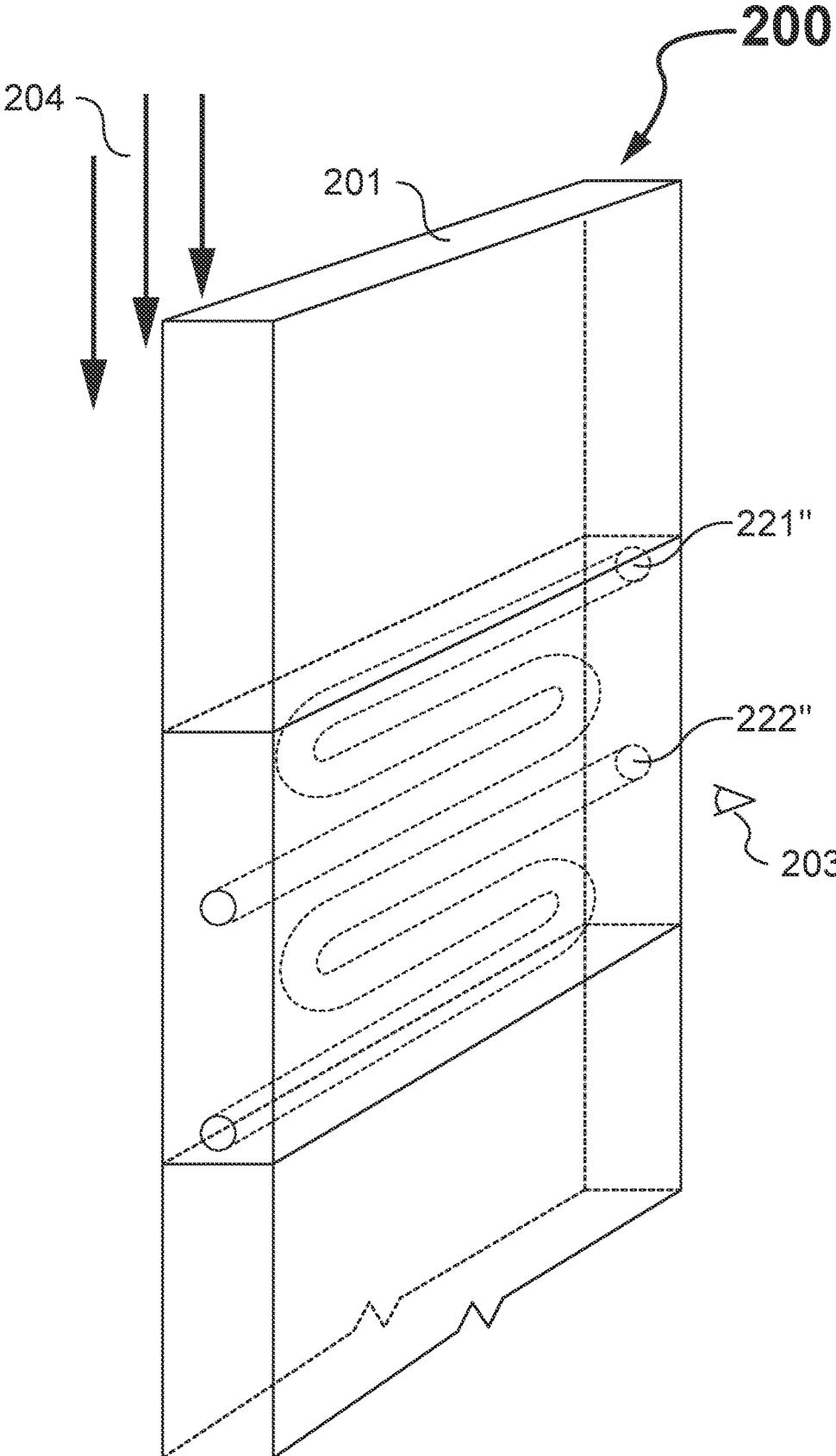

Figure 2c

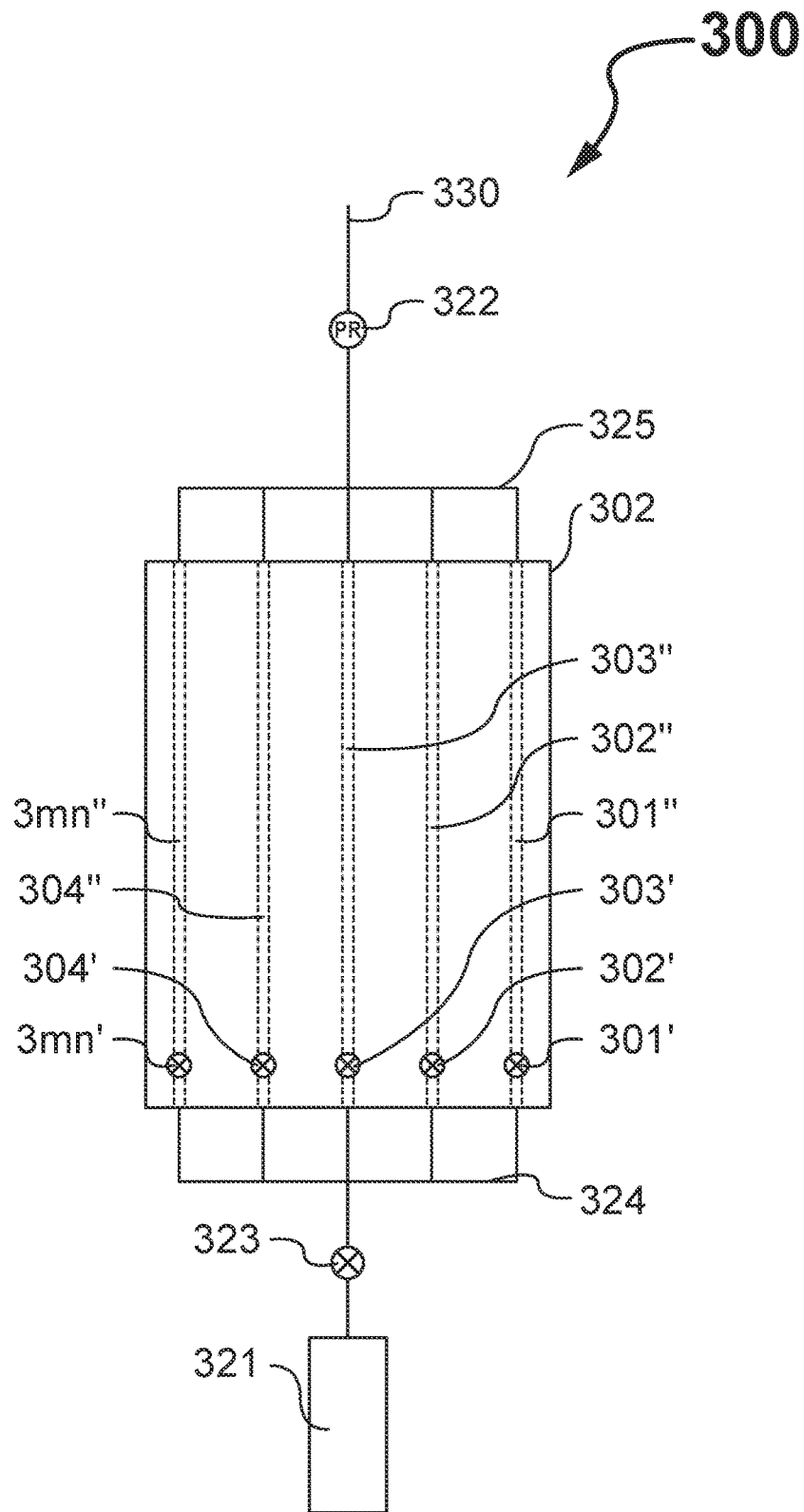

Figure 3

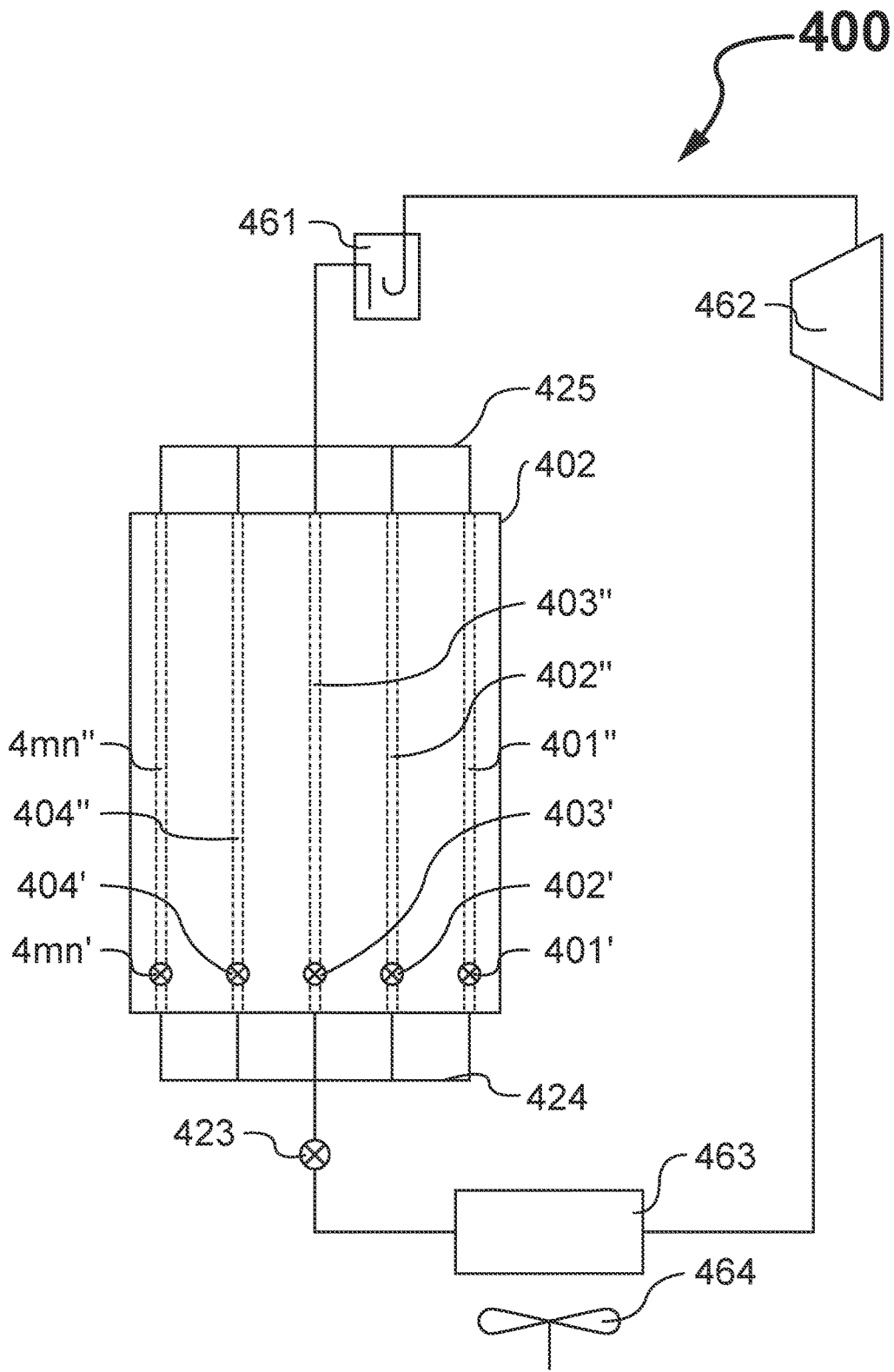

Figure 4

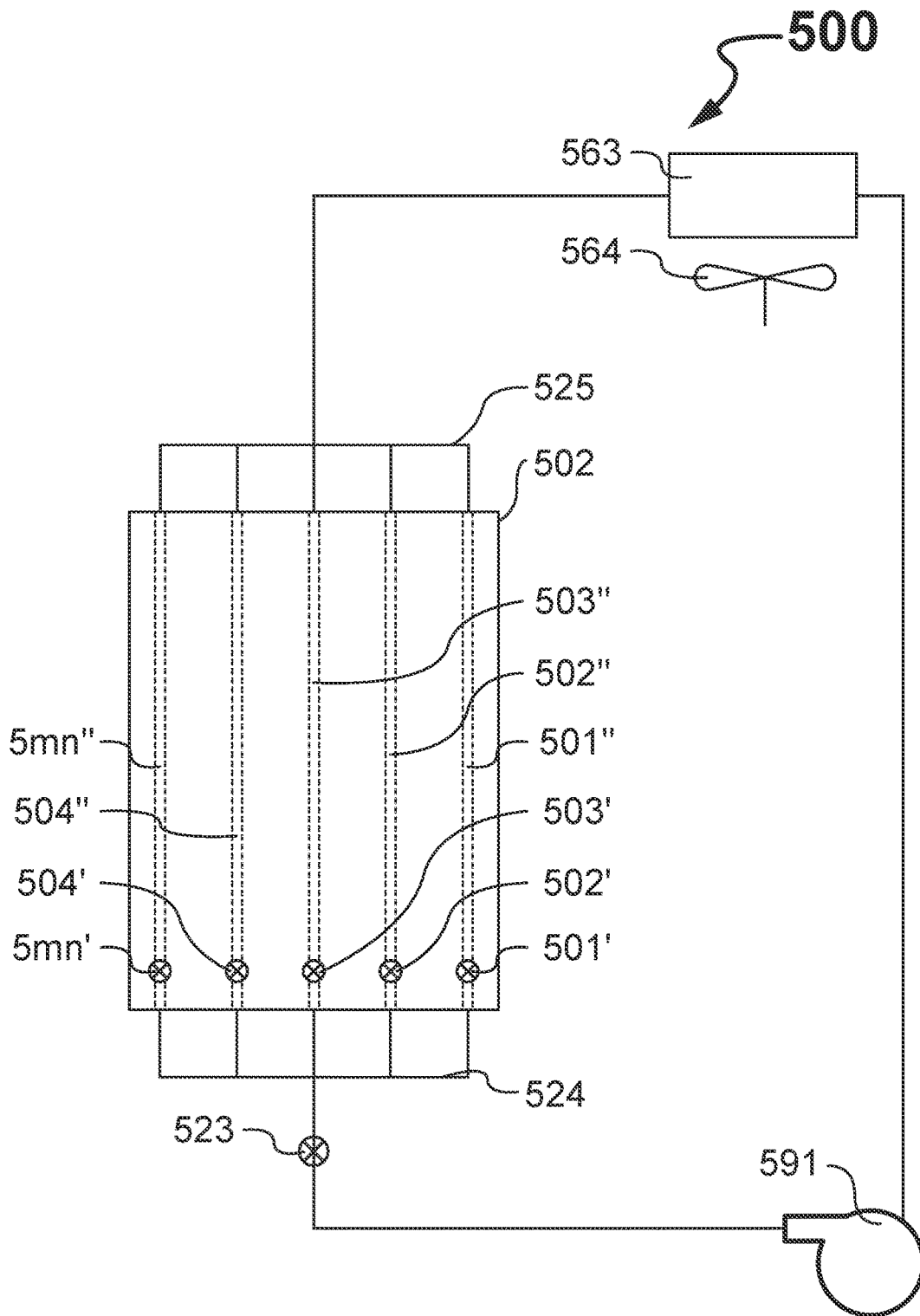

Figure 5

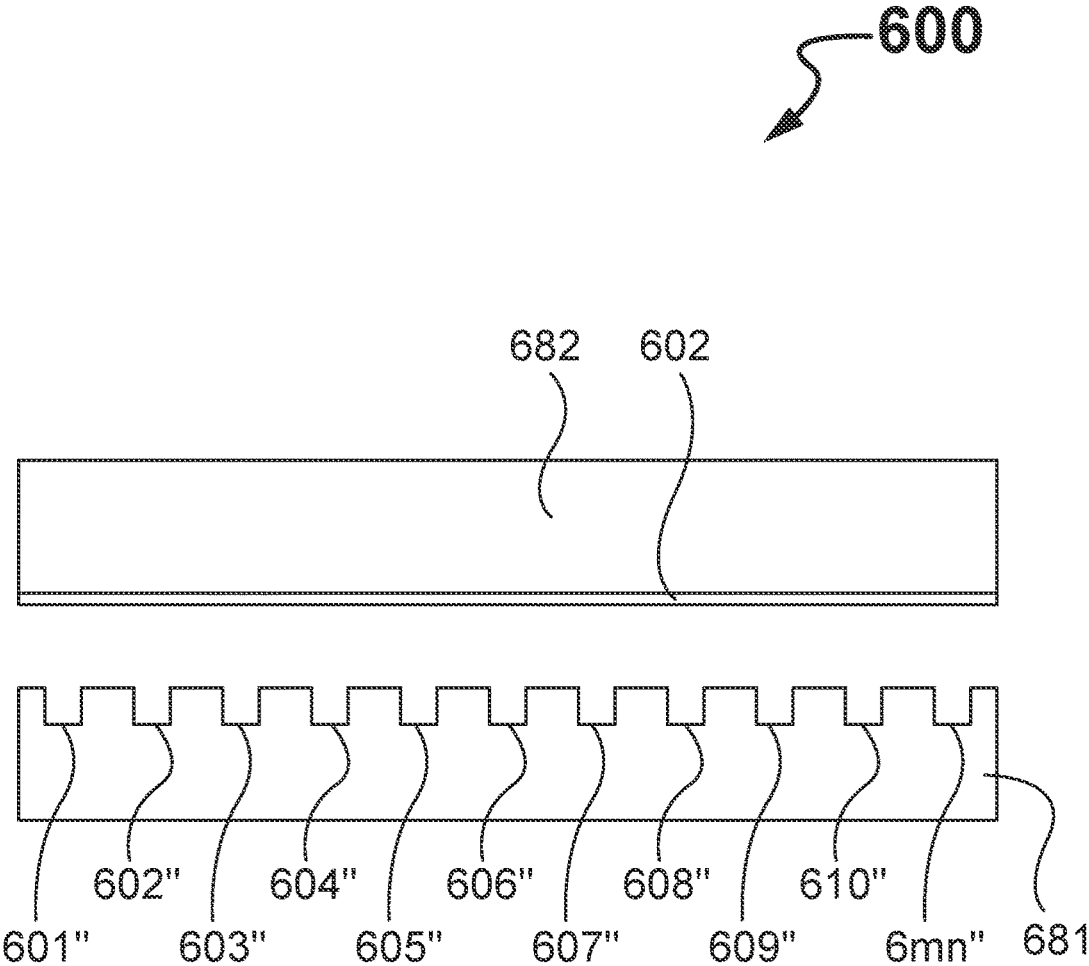

Figure 6

Figure 7a

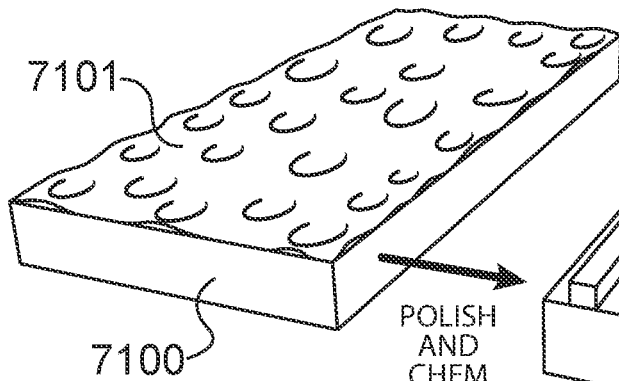
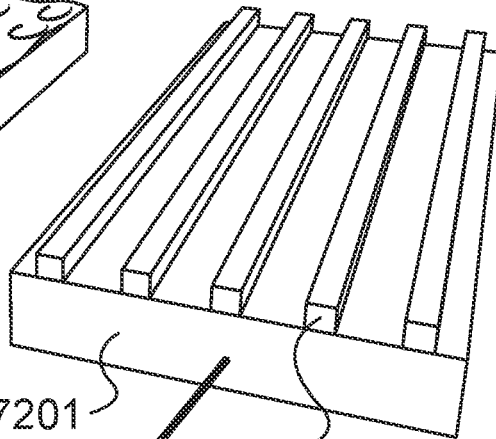
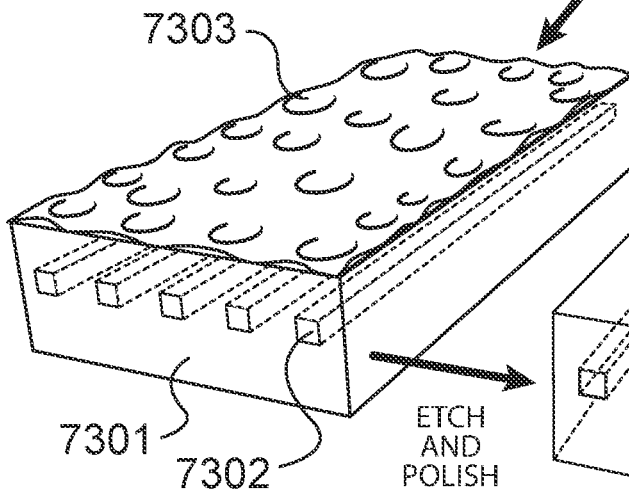

Figure 7b



POLISH AND CHEM TREAT

Figure 7c



GROW MORE

Figure 7d

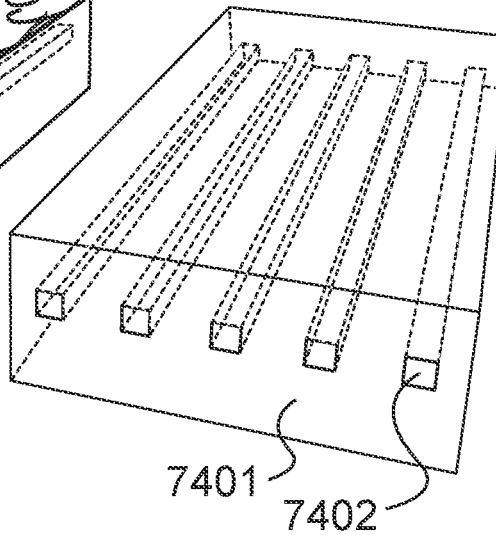

ETCH AND POLISH

Figure 8a

Figure 8b

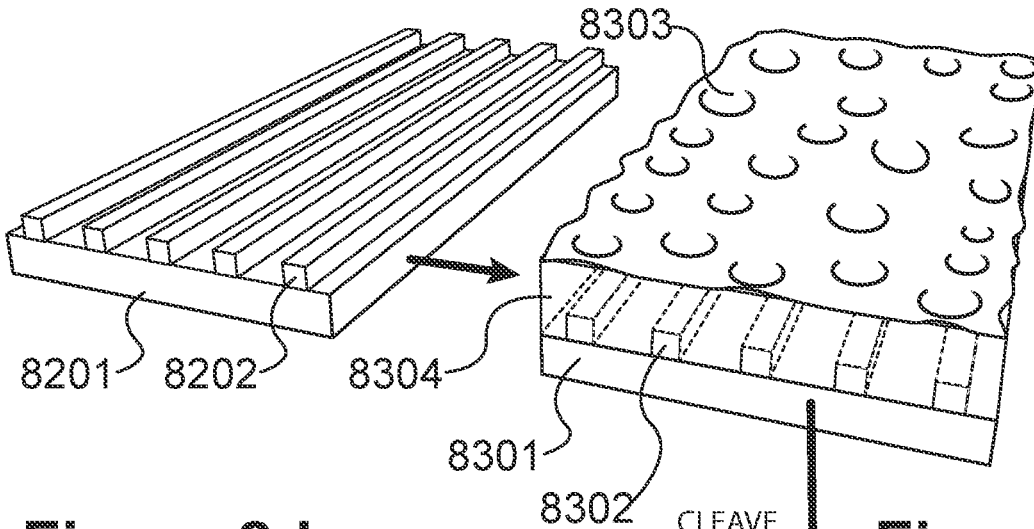

Figure 8d

Figure 8c

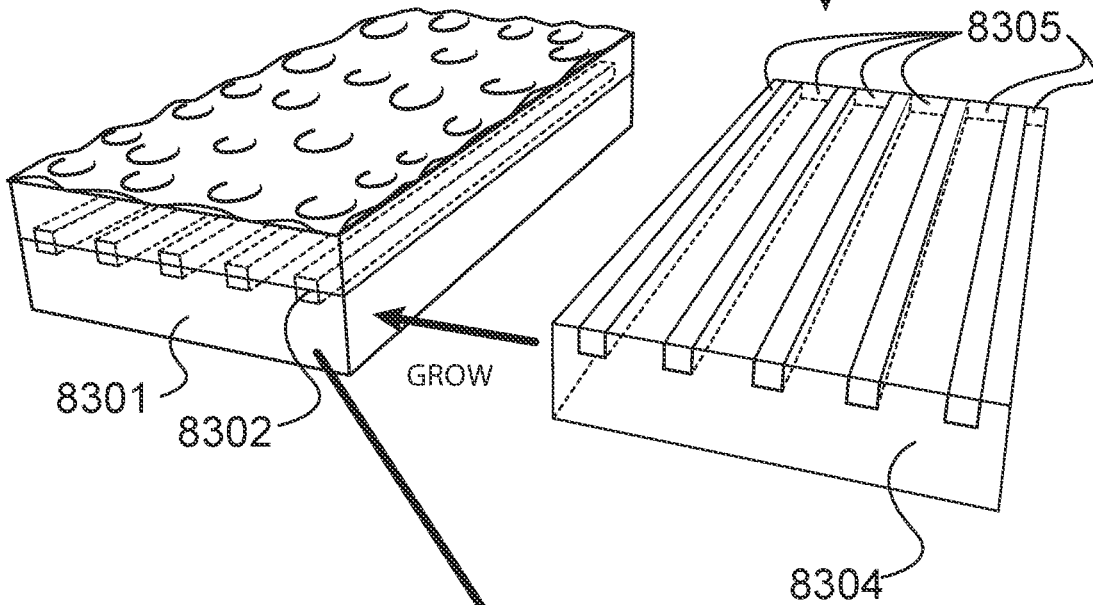
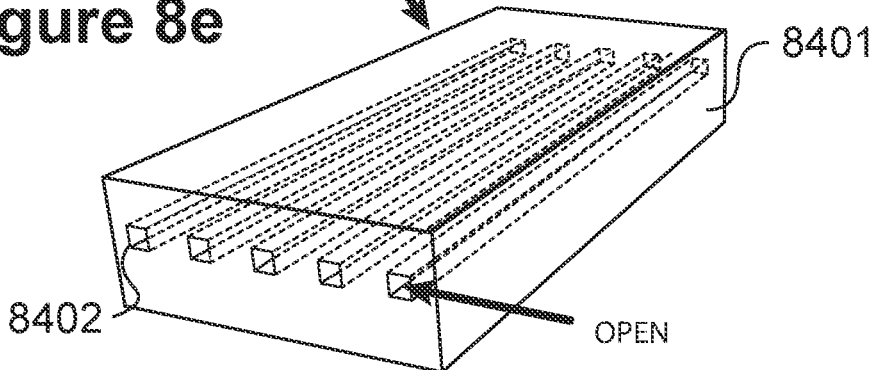

Figure 8e



**ADVANCED COOLING SYSTEM USING
THROTTLED INTERNAL COOLING
PASSAGE FLOW FOR A WINDOW
ASSEMBLY, AND METHODS OF
FABRICATION AND USE THEREOF**

CROSS-REFERENCE TO RELATED
APPLICATIONS

This application is a continuation of U.S. patent applica- 10
tion Ser. No. 16/745,927, filed Jan. 17, 2020, now U.S. Pat.
No. 10,914,529, and a continuation of U.S. patent applica-
tion Ser. No. 16/745,966, filed Jan. 17, 2020, and a continu-
ation of U.S. patent application Ser. No. 16/745,982, filed
Jan. 17, 2020, all of which are incorporated by reference
herein in its entirety, and which these applications are
continuations of U.S. Ser. No. 15/478,474, filed Apr. 4,
2017, now U.S. Pat. No. 10,591,221, all of which is incor-
porated by reference herein in its entirety. This application
is related to co-pending U.S. patent application Ser. Nos.
16/747,038 and 16/747,042, the subject matter of each is
incorporated herein by reference. This application is related
to co-pending application entitled ADVANCED COOLING
SYSTEM USING THROTTLED INTERNAL COOLING
PASSAGE FLOW FOR A WINDOW ASSEMBLY, AND
METHODS OF FABRICATION AND USE THEREOF
having the first named inventor Tucker, Brian P. having the
Ser. No. 17/187,998 and being filed contemporaneously.

BACKGROUND AND SUMMARY OF THE
INVENTION

The present invention relates generally to thermally con- 15
trolled systems for infrared and other wavelength optical
windows that are exposed to extreme high and low temper-
atures and their production, such systems allowing their
use in these extreme environments by actively cooling or
heating the window, respectively, via flow passages internal
to the window. In the case of window heating, that situation
would typically be required to prevent icing and/or conden-
sation since, in general, a cold window does not hinder
transmission.

Infrared (IR) windows are currently unable to survive the
environment experienced by hypersonic vehicles traveling
above Mach 3. Window temperatures can exceed 900° C.
from exposure to the high heat fluxes and temperatures
associated with hypersonic flight. A typical prior art IR
window **102** on a section of a hypersonic vehicle designated
generally by numeral **100** employing a sensor **103** (sche-
matically illustrated), such as an IR sensor, is shown in FIG.
1. The high-speed air **104** flows along or against the exterior
surface **105** of the window, thereby generating heat which
will destroy the window or render the window opaque to the
wavelength of light being sensed or monitored by the sensor
103.

Optical windows and domes used in hypersonic aircraft,
missile systems and spacecraft for infrared imaging or other
wavelength imaging demand good mechanical stability and
high optical transmission in the wavelength range of the
sensor that is viewing through the window. For infrared
sensors, the wavelength range is typically between 0.4
micron and 12 microns. Zinc sulfide, zinc selenide, germa-
nium, gallium arsenide, gallium phosphide, and cadmium
telluride are used in applications such as IR windows which
require long wavelength infrared (LWIR) optical transmis-
sion capability. The fabrication of zinc sulfide and zinc
selenide via chemical vapor deposition (CVD) routes is one

possible pathway. Alternatively, IR windows can be pro-
duced by forming a green body from a population of
nanoparticles, depositing a layer of ZnS powder and sinter-
ing the covered green body to produce a sintered product.

5 One known window assembly consists of an outer win-
dow and inner window with an intervening space which can
be filled by a material characterized by high thermal insu-
lation properties or, alternatively, a cooling fluid is circulated
through an intervening space so that, the entire intervening
10 space between the outer and inner windows is filled with
either an insulating gas or a cooling fluid. There are signifi-
cant drawbacks to this approach. Since the sensor must look
through the cooling or insulating fluid in the intervening
space, the inner window is coated with an optical coating
15 that is substantially transparent at the visible and/or the
infrared frequency portion of the electromagnetic spectrum to
reduce reflections because the two liquid-to-window inter-
faces can cause reflection or variation of the wavelength,
resulting in noise in the IR signal and reduced quality. Yet
20 another drawback of this type of assembly is that, because
the interior flow cross-section created by the intervening
space is simply a wide-open unsupported area, it has less of
an ability to withstand a large pressure gradient between the
fluid in the intervening space and the interior or exterior of
25 the window. Also, the open flow cross-section of the inter-
vening space means that there are no defined flow passages
or flow paths in intervening space, but rather only an open
cross-section. Therefore, without any such flow constraints,
uniform flow across the intervening space is problematic in
30 that fluid flow can be expected to take the shortest path from
the inlet to outlet, leaving other areas with little or no flow,
resulting in large temperature variations across the window.
While this type of prior art proposed the coolant as a
single-phase liquid or gas, flow maldistribution would have
35 been an even greater problem if an evaporating fluid had
been contemplated, because the highly variable g-forces
experienced in a hypersonic vehicle or missile will further
exacerbate this flow maldistribution and potential flow insta-
bilities. This is because the inertial effects on the liquid and
40 vapor in the coolant passage will be different.

Another known window assembly includes an inner win-
dow, an outer window, and a support subsystem between the
inner and outer windows defining a plurality of infrared
transparent fluid flow cooling channels for cooling the outer
window without adversely affecting the optical properties of
45 either window. Like the assembly just discussed, this second
known approach also proposes to have transparent fluid flow
cooling passages. We have recognized, however, that it is
disadvantageous for wavelengths of interest for the sensor to
be transmitted through the cooling passages as that will
50 adversely affect the sensor data and also that opaque cooling
passages are a solution to that problem.

A conceptual silicon window cooled using single-phase
water has also been described by Wojciechowski et al
55 (Internally Cooled Window for Endoatmospheric Homing,
AIAA, May 1992). We have found, however, that the use of
single-phase water causes undesirably lower heat transfer
coefficients and requires equally undesirable large mass flow
rates to maintain a uniform temperature. Furthermore, the
silicon cooled window concept is only applicable to MWIR
60 since silicon substrate absorbs in LWIR.

Zinc sulfide is a common material for LWIR and semi-
active laser windows and domes. Multi-spectral zinc sulfide
(ZnS), made by CVD, is also commercially available. A
sintering process is believed to produce a more erosion-
resistant and ultra-high density IR window. Regardless of
65 the base material being used, or the manufacturing process

used to form these windows, they must be actively cooled because of the very high thermal loads that result from the high-speed airflow over the exterior during flight. Currently available IR window materials are still unable to withstand the heat fluxes and temperatures associated with these conditions. Future missile performance improvements will be impeded without the development of advanced cooling strategies for high-speed weapon windows.

We have discovered a way to address these problems by employing an internally cooled IR window that uses two-phase flow in one or more channels having hydraulic diameters less than about 0.118 inch (3 mm) within the window to maintain both a uniform temperature, a low mass flow rate (relative to single-phase flow which results in lower pressure drops) and a low temperature while also minimizing system size. The passages are optically non-transparent to a monitored or sensed light wavelength. An inlet flow restriction or valve such as an orifice, weir (partial dam of the cross-sectional flow area), capillary tube section, reduced hydraulic diameter section or adjustable throttling valve (such as a thermostatic expansion valve (TXV) or electronic expansion valve (EXV)) is provided at the inlet of each flow passage in the IR window to act as a throttling device upstream of the evaporation section of the cooling passages which will, for two-phase evaporating coolants, initiate adiabatic nucleation (i.e., evaporation) and prevent boiling (evaporation) hysteresis. This flow restriction will also act as a flow balancing mechanism for two-phase coolant flow and even single-phase coolant flow, since the pressure drop across this restriction will substantially exceed pressure drops due to the flow down an individual passage, pressure variations due to orientation, and pressure variations due to external g-forces. For two-phase coolants, the pressure drop of the flow restriction will make perturbations in the pressure drop in the two-phase coolant passageway, i.e., perturbations potentially resulting from variations in the thermodynamic quality due to variations in heat loading applied to the window, insignificant relative to the pressure drop across this upstream throttling device. This throttling device can be located at the inlet of the IR window, at the interface between the window and the inlet flow manifold or at the exit of the inlet manifold. Such a configuration keeps the flows in balance at the design flow rates, regardless of changes in g-forces, orientation, and thermodynamic flow quality due to non-uniform heat loading on the coolant passages or the window itself. In addition, either an upstream (upstream of the IR window) control or throttling valve can be used along with the passage flow restrictions to control the superheat or quality exiting the actively cooled window. As part this discovery process, we have considered the effects of material light absorption and emission, channel emission, channel diffraction, and temperature-induced wavefront deformation. At the same time, we have discovered as well, a novel method to fabricate these windows with internal cooling passages for using two-phase flow. One of many advantages of our discoveries is that they provide significantly better performance than any previous internally cooled window that has been demonstrated in the prior art such as those which use two-phase ammonia impinging onto a porous cover and vent coolant directly in front of the window (which can significantly degrade image quality) or require bonding of the window, a stainless-steel coolant tube, and a porous cover.

BRIEF DESCRIPTION OF THE DRAWINGS

These and other objects, features and advantages of our invention will become more readily apparent from the

following detailed description when taken in conjunction with the accompanying figures wherein:

FIG. 1 depicts a known type of IR window used as part of a section of a hypersonic vehicle, such as a missile, rocket or high speed airplane, employing a sensor which views through the IR window as above described.

FIGS. 2a, 2b and 2c are, respectively, embodiments of an actively cooled IR window used on a hypersonic vehicle, such as a missile, rocket or high speed airplane, employing a sensor which views through the actively cooled window which has parallel-flow passages, series-flow passages or a combination of parallel- and series-flow passages.

FIG. 3 is a schematic drawing of an open-loop IR window cooling system configuration where liquid coolant stored in the reservoir flows through the passages in the IR cooled window to prevent any thermally related damage to the IR window.

FIG. 4 is a schematic drawing of a closed-loop IR window cooling system configuration where liquid coolant in the actively cooled window is the evaporator of a vapor compression cooling loop.

FIG. 5 is a schematic drawing of a closed-loop pumped two-phase IR window cooling system configuration where liquid coolant in the actively cooled window is the evaporator of a pumped two phase thermal control loop.

FIG. 6 is an isolated schematic view of an embodiment of our invention in which an internally cooled IR window is fabricated from multi-spectral zinc sulfide (ms-ZnS) or single-crystal Zinc Sulfide plate-like material.

FIGS. 7(a)-(d) show a currently contemplated method according to our invention to obtain high aspect ratio inner channels by CVD growth, after polishing, continuing after placement of a selectively removable core-channel forming material.

FIGS. 8(a)-(e) shows another embodiment of a method according to our invention to obtain the same result as in FIG. 7(a)-(d) but with removal of the polishing step between the two CVD growth steps to form the inner channel material around the core material.

DETAILED DESCRIPTION OF THE DRAWINGS

An embodiment of a novel window designated generally by numeral **200** in accordance with our invention is shown in FIG. 2a. Once again, hypersonic or simply high speed airflow **204** over or against the outer surface causes heat generation on the vehicle surface and the window. We recognized that to keep the window from failing or preventing proper visibility to a known type of sensor **203** (schematically shown) requires that the window be actively cooled. In this currently contemplated embodiment of the present invention, one or more cooling passages **201"-2mn"** (mn being used herein to designate the last of any number of desired parts in a series) are arranged inside the window **200** to provide cooling to maintain the window at a survivable temperature, so that near isobaric evaporation of the coolant inside the passages **201"-2mn"** also provides near isothermal temperature distribution given that the evaporation temperature is directly related to the evaporation pressure which is nearly isobaric. This nearly uniform temperature distribution translates into less thermal distortion of the wavelength being observed by the sensor **203**. A small restrictor or adjustable throttling valve can be arranged at the entrance to each passage (shown in FIGS. 3, 4 and 5) or, alternatively, in an interface between a manifold and the entrance of the passages to act as a throttling device upstream of the evaporation section of the cooling passages to initiate nucle-

ation and also as a flow balancing system to prevent flow instabilities, such as manometer tube parallel-path flow oscillations to name but one possible flow instability being prevented. The sensor 203 can, for example, be a long wavelength Infrared (LWIR) sensor, medium wavelength infrared (MWIR) sensor, a short wavelength infrared (SWIR) sensor or even a visual sensor or camera. It will now be understood in the art that, while only parallel-flow passages have been shown as an exemplary embodiment, series-flow passages (211" in FIG. 2b) or combinations of series- and parallel-flow passages (221", 222" in FIG. 2c) can also be used within the scope of the present invention.

In one currently preferred embodiment of our invention, the actively cooled window is an IR window cooling system which is cooled by the evaporation of the coolant flowing through the IR window and can be configured in either a closed-loop or open-loop system. Of course, it will now be appreciated by one skilled in this art that all types of windows can employ the present invention, and that a window transparent to LWIR is perhaps the most challenging application of our technology due to limited available material options and the processing abilities of those available materials.

With regard to the type of window assembly shown in FIG. 2a, an open-loop IR window cooling system configuration designated generally by numeral 300 is shown in FIG. 3 where coolant stored in a reservoir 321 flows through an optional control or throttling valve 323 then enters an inlet flow distributing manifold 324 before being directed into the individual flow passages 301" through 3mm" located inside the IR window 302. An inlet flow restriction or valve 301' through 3mm' such as an orifice, weir, capillary tube section, reduced hydraulic diameter section or adjustable throttling valve (such as a TXV or EXV) is provided at the inlet of each flow passage in the IR window to act as a throttling device upstream of the evaporation section of the cooling passages 301" through 3mm" which will initiate adiabatic nucleation (i.e., evaporation) and prevent boiling (evaporation) hysteresis, and also to act as a flow balancing system since the pressure drop across this restriction will outweigh the pressure drops due to the two-phase flow down an individual passage, thereby making perturbations in the pressure drop in the two-phase coolant passageway (potentially as a result of variations in the thermodynamic quality) insignificant relative to the pressure drop across this upstream throttling device. This throttling device can be located at the inlet of the IR window, at the interface between the window and the inlet flow manifold or at the exit of the inlet manifold. Even if a single-phase coolant fluid is used as the cooling fluid in the embodiments disclosed herein and contemplated as part of our inventive concept, such a configuration keeps the flows in balance or at the design flow rates, regardless of variations in g-forces, orientation, and thermodynamic flow quality (caused by non-uniform heat loading on the coolant passages or the window itself). Either the optional control or throttling valve 323 or the individual flow restrictions 301' through 3mm' or both can be used to control the superheat or quality exiting the open loop system at the outlet to the environment 330. In a currently preferred embodiments of our invention, a variety of two-phase coolants or mixtures thereof including water, ammonia, liquid nitrogen, liquid helium, liquid neon, liquid argon, liquid krypton, liquid xenon and other liquefied gases as well as conventional refrigerants including hydrofluorocarbon (HFC) refrigerants, perfluorocarbon refrigerants, hydrocarbon (HC) refrigerants and hydrofluoro-olefin

(HFO) refrigerants can be used in this configuration as one skilled in the art will now recognize.

The coolant evaporates either partially or completely and then exits the individual cooling passages 301" through 3mm" being combined in an exit flow manifold 325 before flowing into an optional evaporation pressure regulator 322 and then vented either overboard 330 or internally to the vehicle carrying the window assembly. It is well understood by one skilled in the art that the evaporation pressure regulator could be replaced by a temperature or flow regulating valve or that a combination of pressure, temperature and flow can be used to determine the position of the valve 322. It is also understood that the overall cooling could be initiated by opening either valve 323 or 322 and terminated by the complete closing of either valve 323 or 322. Also, the person of skill in the art will understand the greater thermal inertia and thermal capacity that is provided to the IR window if valve 322 is used the control turn on and turn off when compared to using valve 323 to perform those functions. Likewise, one versed in the art will understand that lower pressure is developed in the IR window cooling passages if valve 323 is used the control turn on and turn off as compared to using valve 322 to perform those functions.

FIG. 4 displays another embodiment of our closed-loop IR window cooling system configuration designated generally by numeral 400 where liquid coolant flowing from a condenser 463 flows through an optional control or throttling valve 423 then enters an inlet flow distributing manifold 424 before being directed into individual flow passages 401" through 4mm" located inside an IR window 402. At the inlet of each flow passage in the IR window there is an inlet flow restriction or valve 401' through 4mm' such as an orifice, weir (partial dam of the cross-sectional flow area), capillary tube section, reduced hydraulic diameter section or adjustable throttling valve (such as a TXV or EXV) to act as a throttling device upstream of the evaporation section of the cooling passages 401" through 4mm" which will initiate adiabatic nucleation (i.e., evaporation) and prevent boiling (evaporation) hysteresis and also act as a flow balancing system since the pressure drop across this restriction will outweigh the pressure drops due to the two-phase flow down an individual passage, thereby making perturbations in the pressure drop in the two-phase coolant passageway (potentially as a result of variations in the thermodynamic quality) insignificant relative to the pressure drop across this upstream throttling device. This throttling device can be located at the inlet of the IR window, at the interface between the window and the inlet flow manifold or at the exit of the inlet manifold. Again, even if a single-phase coolant is used, such a configuration keeps the flows in balance or at the design flow rates, regardless of changes in the thermodynamic flow quality due to non-uniform heat loading on the coolant passages or the window itself. Either the control or throttling valve 423 or the individual flow restrictions 401' through 4mm' or both can be used to control the superheat or quality exiting an exhaust manifold 425. The evaporated coolant leaving the IR cooled window 402, hereafter also referred to as the refrigerant, will then flow to a suction line accumulator 461 to assure that only superheat refrigerant vapor enters a compressor 462. If the refrigerant exiting the IR window 402 via the exhaust manifold 425 is typically always saturated and not superheated, then a pumped two-phase loop configuration such as shown in FIG. 5 can be used instead of the vapor compression system shown in FIG. 4, or heat can be added to the suction line accumulator 461 (or heat added to an additional heat exchanger or recuperator upstream of the compressor 462)

prior to the compression of the refrigerant vapor to avoid the steady-state injection of incompressible liquid refrigerant by the compressor 462. Alternatively, if the refrigerant flow exiting the exhaust manifold 425 is typically superheated or is assured to be superheated by feedback control of this information by either the optional control or throttling valve 423 and/or the individual flow restrictions 401' through 4mm' or both then the superheat of refrigerant normally exiting the exhaust manifold 425 or exiting the passages before entering the exhaust manifold will evaporate any transient saturated liquid that may enter the suction line accumulator, due to transient operation. In this way, any short-term transient liquid, due to the rapid changing of power levels or valve settings can be accommodated by the temporary hold-up of this liquid refrigerant in the suction line accumulator 461. A variety of two-phase coolants or refrigerants including water, ammonia, liquid nitrogen and other liquefied gases as well as numerous potential conventional HFC, HFO and HC refrigerants can be used in this configuration as one skilled in the art will now recognize. However, our currently preferred embodiment of two-phase cooling employs two-phase evaporation of water.

The condenser 463 shown in FIG. 4 is air cooled, and the air flow through the condenser can be increased with an optional fan or blower assembly 464. One skilled in the art will understand, however, that this air-cooled condenser can be replaced by a liquid cooled condenser within the scope of our invention. It is also understood that a typical vapor compression system has other common and well-known components such as a filter-drier, high and low pressure safety controls, and liquid receiver to name just a few that would be present in any typical vapor compression system.

FIG. 5 displays yet another embodiment of our invention in the form of a closed-loop pumped two-phase IR window cooling system configuration designated generally by numeral 500 where liquid coolant flowing from a pump 591 through an optional control or throttling valve 523 then enters an inlet flow distributing manifold 524 before being directed into the individual flow passages 501" through 5mm" located inside an IR window 502. At the inlet of each flow passage in the IR window there is an inlet flow restriction or valve 501' through 5mm' such as a orifice, weir, capillary tube section, reduced hydraulic diameter section or adjustable throttling valve (such as a TXV or EXV) to act as a throttling device upstream of the evaporation section of the cooling passages 501" through 5mm" which will initiate adiabatic nucleation (i.e., evaporation) and prevent boiling (evaporation) hysteresis and also act as a flow balancing system since the pressure drop across this restriction will outweigh the pressure drops due to the two-phase flow down an individual passage, thereby making perturbations in the pressure drop in the two-phase coolant passageway (potentially as a result of variations in the thermodynamic quality) insignificant relative to the pressure drop across this upstream throttling device. This throttling device can be located at the inlet of the IR window, at the interface between the window and the inlet flow manifold or at the exit of the inlet manifold. Such a configuration keeps the flows in balance or at the design flow rates, regardless of changes in the thermodynamic flow quality due to non-uniform heat loading on the coolant passages or the window itself. Either the control or throttling valve 523 or the individual flow restrictions 501' through 5mm' or both can be used to control the superheat or quality exiting an exhaust manifold 525. The two-phase or superheated refrigerant (coolant), leaving the IR cooled window 502 will then flow to a condenser 563. Only liquid refrigerant should exit the

condenser 563 so that it can be pumped, without cavitation, by the liquid pump 591. The condenser 563 shown is air cooled in the illustrated embodiment and the air flow through the condenser 563 can be increased with an optional fan or blower assembly 564. One skilled in the art will again understand that an air-cooled condenser can be replaced by a liquid cooled condenser within the scope of our invention. It is also understood that a typical two-phase pumped loop system has other well-known common components such as a pressurizer and liquid receiver to prevent pump cavitation and to control the condensation and resulting evaporation temperatures to name just a few that would be present in any modern two-phase pumped loop system. One skilled in the art will now further recognize that a single-phase pumped cooling loop could also be employed within the scope of our invention instead of our currently preferred pumped two-phase cooling loop using, by way of example only, water. The pumping power in the single-phase pumped cooling system would, however, be greater due to the requirement for additional mass flow rate of the single-phase coolant. A variety of two-phase coolants or refrigerants including water, ammonia, liquid nitrogen and other liquefied gases as well as numerous potential conventional HFC, HFO and HC refrigerants can be used in this configuration as one skilled in the art will also now recognize.

We have investigated materials that can be fabricated with internal cooling passages and used for our active cooling window as shown in Table 1 below. Unfortunately, most materials that transmit LWIR are also incapable of handling the high temperatures and stresses associated with hypersonic flight so active cooling is necessary. It is well known in the art that candidate materials that do not absorb LWIR at all are diamond, germanium, zinc selenide, and gallium arsenide. Germanium is unsuitable for a hypersonic environment because free-carrier absorption renders the window useless above 100° C. and a high thermo-optic coefficient ($400 \times 10^{-6}/^{\circ}\text{C}$.) significantly distorts the signal during high heat fluxes. Zinc selenide (ZnSe) is generally considered unsuitable for supersonic applications because its low hardness makes it very susceptible to erosion. However, its low thermo-optic distortion makes it an excellent material for applications that do not require durability. Gallium arsenide (GaAs) is a good candidate if the window temperature remains below the free-carrier absorption limit of 400° C., and also has the capability to be used in the MWIR wavelength region. However, GaAs is susceptible to wavefront deformation because of a high index of refraction change with temperature ($dn/dT=150 \times 10^{-6}/^{\circ}\text{C}$.) and low thermal conductivity (48 W/m-K). Of course, our two-phase active thermal control is able to reduce the temperature gradient of the window, thereby mitigating optical distortion caused by the high index of refraction change with temperature. As was known prior to our invention, diamond is an ideal material for the hypersonic environment in that it has the best thermal conductivity, lowest thermo-optic coefficient, and highest hardness but its use is currently limited by cost, availability, and a maximum temperature of 700° C. (as set by the oxidation limit).

Since some absorption of the IR signal can be tolerated, five additional materials can be considered. Float zone silicon (FZ-Si) offers high erosion resistance and strength and has previously been used. Gallium phosphide (GaP) provides good erosion resistance and minimal wavefront deformation but has high LWIR absorption and is not commercially available. ZnS offers improved erosion resistance relative to ZnSe at the cost of increased temperature-induced wavefront distortion and a decrease in performance

from absorption. Tuftran™ (ZnSe with a ZnS coating), combines the low absorption of ZnSe with the improved erosion resistance of ZnS. However, the low strength and thermal conductivity of the ZnSe layer leads to problems with thermal shock at high heat fluxes. The mismatch in the thermal expansion coefficients of the two materials also can lead to delamination of the layers. Finally, our currently preferred embodiment for a LWIR window uses multi-spectral Zinc Sulfide (ms-ZnS) which is sold under the registered trademark "CLEARTRAN" © of Dow Chemical and is formed by modifying ZnS to be water free by a hot isostatic pressing process because it removes most LWIR absorption and all MWIR absorption at, however, the expense of some reduced strength and hardness. Gallium arsenide (GaAs) is another good candidate for MWIR windows as long as the window temperature remains below the free-carrier absorption limit of 400° C., which of course is possible with the active thermal control disclosed in this invention.

TABLE 1

Properties of LWIR Window Materials								
Property [Units]	Germanium	ZnSe	GaAs	Diamond	Float Zone Silicon	Gallium Phosphide	ZnS	ms-ZnS
Thermal Conductivity [W/m-K]	59	18	48	2000	159	110	17	27
dn/dT	408	61	149	15.6	150	137	41	54
Strength [MPa]	93	55	138	≈300	125	≈100	103	69
Maximum Temperature [° C.]	100		400	700	260	600	600	600
Absorption in MWIR at Room Temperature	No	No	No	Very High	No	No	High	No
Absorption in LWIR at Room Temperature	No	No	No	No	High	High	Moderate	Low
Commercially Available	Yes	Yes	Recently	High Cost	Yes	No	Yes	Yes
Knoop Hardness [kg/mm ²]	692	105	750	8260	1150	840	210	150

Many of the materials listed in Table 1 above also perform well in the MWIR band. The ms-ZnS is also a good MWIR material because it does not absorb at all in this region. If improved performance is desired, FZ-Si also does not absorb in the MWIR region while offering higher mechanical strength and a higher thermal conductivity (less coolant channel blockage because channels can be spaced further apart). Additional MWIR-only materials are listed in Table 2 below. Sapphire is desirable because of its thermal conductivity, hardness, and strength. However, it also absorbs significantly at high temperatures. At 427° C., a 2 mm thick sapphire window has an emittance of 0.34, which can significantly affect performance. Yttria has minimal high-temperature absorption but has issues with thermal shock because of low thermal conductivity and relatively low strength; it is also not yet commercially available. We currently contemplate using one or more of the above materials in forming the window according to the processes described hereinbelow.

TABLE 2

Properties of MWIR Window Materials					
Property (Units)	Yttria	Sapphire	ALON	Spinel	MgF ₂
Thermal Conductivity [W/m-K]	13.5	36	12.6	14.6	14.7

TABLE 2-continued

Properties of MWIR Window Materials					
Property (Units)	Yttria	Sapphire	ALON	Spinel	MgF ₂
dn/dT	30	6-12	2.8	3	1
Strength [MPa]	160	300	300	190	125
Maximum Temperature [° C.]	—	—	—	—	—
Absorption in MWIR at Room Temperature	Low	Moderate	Moderate	Very High	Low
Absorption in LWIR at Room Temperature	Very High	100%	100%	100%	Very High
Commercially Available	Yes	Yes	Recently	High Cost	International
Knoop Hardness [kg/mm ²]	720	2200	1800	1600	580

Temperature adversely affects a window in three ways. The first is that most IR window materials absorb some of the signal passing through the window, and this absorption

increases with the temperature of the window. For example, a 0.8 cm thick ms-ZnS window at room temperature absorbs 9% of the LWIR energy passing through it. However, at 150° C., it will absorb 15% of the energy passing through and at 600° C., it is expected that 29% of the energy passing through is absorbed. The second is that, like any surface at elevated temperature, the window radiates far more energy, and at the higher temperatures the energy radiated actually limits performance more than wavelength absorption. Using the definition of normalized Target Acquisition Range (TAR) as the actual TAR (i.e., the distance that a target becomes visible to an IR sensor through a window) divided by the unencumbered or ideal TAR (i.e., the distance at which a target is visible if no window were present), at a window temperature of 600° C., the actual TAR is reduced to only 48% of the ideal TAR (normalized TAR is 0.48). The third is that many materials will oxidize or decompose at high temperatures, rendering the window opaque or even destroying the window entirely. It is well known in the art that, for IR sensor windows to be used in hypersonic applications, active cooling is absolutely necessary. Up until our present invention, however, the problem of useful active cooling had not been solved.

Our invention is specifically engineered so that the wavelength of the sensed or monitored light that happens to strike the cooling passages rather than the window area between the passages is not transmitted through the passages. For improved image quality and to avoid distortion, we have

been able to avoid passing the wavelengths of light of interest to the sensor or being monitored through the cooling passages and to assure that they pass only through the area where there are no cooling passages. The cooling passages are configured to be non-transparent to the wavelengths of light being sensed or monitored by, for example, applying a coating to the inside surfaces of the passages, using passages with opaque walls (such as hollow cores as described below) and/or other techniques for preventing transmission. Even if the liquid coolant fluid is already opaque, in a two-phase coolant application, the vapor may not be transparent, or the different index of refractions between the liquid and vapor coolant can lead to signal distortion, noise in the sensed signal, and other optical issues. Our invention allows the use of any evaporating two-phase fluid, transparent or non-transparent, because of the absorbing coating or other type of coating that is applied to the inside of the passage walls to make the surface non-transparent and/or absorb any radiation (light) in the sensor wavelength, and thereby provide a clear sensor signal while avoiding any optical signal noise caused by transmission of the wavelengths through the passage and to the sensor. This coating on the inside surfaces, as well as exploiting any inside passage surface finish benefits that can be obtained by our core manufacturing process, avoid any issues associated different indexes of refraction at the passage's fluid-solid interface or evaporating liquid-vapor interface.

Our invention also allows the use of two-phase evaporation of the working fluid which results in far lower mass flow rates, improved temperature uniformity along the passage length, and significantly higher heat transfer coefficients, which thereby permit the use of smaller (optically opaque to the sensed wavelengths) passages, making less of the window frontal area non-transparent to the signal being monitored or sensed. By way of example, one currently preferred embodiment of our invention uses two-phase water coolant in a ms-ZnS LWIR window, where the cooling passage geometry has been optimized for LWIR operation. The ZnS window material is modified to be water-free by a known hot isostatic pressing process thereby forming ms-ZnS. This embodiment has similar calculated performance relative to an uncooled LWIR window up until the uncooled window begins to oxidize at 650° C. and is rendered useless, demonstrating that active cooling is essential. Our cooling passages in the LWIR window have been shown to reduce the actual TAR of the sensor located behind the window to half the ideal TAR when operating at room temperature.

We have also found that, by using two-phase evaporative water cooling to control the window temperature instead of single-phase sensible water cooling, our system achieves both improved isothermality, and requires that the volume of coolant needs to be only 1% of the volume that would be required for a single-phase water system that exhibits the same thermal performance. Our invention is able to use far smaller passages without experiencing an excessive and unwanted pressure drop, as well as a far smaller liquid water reservoir in the case of an open system, and far smaller overall system in the case of a closed vapor compression system or two-phase pumped loop system. We have also found that even the use of two-phase ammonia evaporation as an alternative two-phase coolant in our invention will increase the actual TAR by 20% (i.e., by a factor of 1.2) although the volume of cooling fluid required is increased by a factor of 3.

FIG. 6 shows an embodiment of our internally cooled IR window that has been fabricated from plate-like material, transparent to the wavelengths being sensed or monitored. A

window 600 with internal flow passages is formed by bonding a base plate 681 with a cover plate 682. The base plate 681 has uniform internal coolant passages 601" through 6mm" machined into the surface of the base plate 681. While the cover plate 682 can also be machined with fluid passage grooves, a flat cover plate 602 is bonded to the base plate 681 in the illustrated embodiment to form the passages 601" through 6mm". By way of one specific example, we manufactured 4.7 inch (long)×4.1 inch (wide) LWIR windows that can be used in the FIG. 3, 4 or 5 embodiments from both ms-ZnS and single-crystal zinc sulfide material. Each window contained thirty-three coolant passages of 0.020 inch (0.5 mm) width×0.060 inch (1.5 mm) depth [i.e., with a hydraulic diameter of 0.030 inch (0.75 mm)], and a passage length of 4.7 inches (119.4 mm). The inlet of each of these flow passages contained identical inlet capillary flow restrictions with a reduced hydraulic diameter section that spanned the initial 0.109 inch (2.77 mm) length of the inlet passage. The diameter of the reduced hydraulic section creating the upstream flow restrictions in the IR window cooling passages varied from 0.007 inch (0.178 mm) to 0.0105 inch (0.267 mm). While rectangular windows have been shown in the figures and in this example, one skilled in the art will now recognize, that the window geometry could be square, round, oval or essentially any shape. Likewise, one skilled in the art will now recognize, that the cooling passages could be round, square, rectangular, triangular or essentially any shape.

In addition to the use of adhesives to bond window plates together to form the coolant passages, if the two surfaces are highly polished and if the particular window configuration would allow edge clamping or mechanical fixturing to hold the two polished surfaces mechanically together, these polished surfaces would not leak and can be used to form a actively cooled window. Furthermore, the window plates could be bonded via optical contacting or diffusion bonding processes which are well known in the art.

We have discovered that, after the cooling passages are fabricated, the preferred method is to etch a rough surface, oxidize the surface, and/or deposit an optical absorbent material on the inside surfaces of the cooling passages so that any IR radiation that hits the cooling passages is absorbed or scattered rather than being transmitted through the coolant passages which might cause IR sensor discrimination issues.

Our preferred method of producing the window is to grow the window material around a solid or hollow core, to form the desired passages. An example of a growth method is chemical vapor deposition (CVD) of group II/VI compounds, such as zinc sulfide. If the core is hollow and non-transparent to the signal being sensed or monitored, the core can be used as the channel. If the core is solid, the core can be removed, still allowing conversion or coating of the surface and leaving a non-transparent channel surface. The core can be chosen such that it can be removed selectively by an etching process, thus leaving one or more passages for coolant flow. Acids attack most group II/VI CVD grown materials, therefore materials which can be dissolved by a base solution are preferred for the core material. The core to be selectively etched can be a metal such as aluminum so as to be selectively removed with an aqueous copper chloride solution. Inasmuch as an amphoteric material can be dissolved by an acid or base, one such as aluminum oxide or copper can be chosen for the core material and dissolved with a base such as aqueous sodium hydroxide. Further, if the core is not adherent to the IR material and has a coefficient of thermal expansion (and contraction) greater

than that of the IR material then the core material may be removed by cooling (the window and core) and then pressing the core out of the window with simple mechanical force (if the core extends to the edges of the window). This process is not limited solely to the production of IR windows.

Alternatively, since IR windows can be produced by forming a body from a population of nanoparticles, depositing a covering layer of ZnS powder on the body and sintering the covered body to produce a sintered product, the core can be imbedded into the body, that is formed around the core. In this way, after the sintering of the green body, the core can then be mechanically or chemically removed, in the same or similar fashion used in the CVD fabricated window with internal coolant passages.

For window designs where the individual passages extend to the edges of the material (after core removal), the coolant passages interface with both inlet and outlet manifolds external to the window. Alternatively, the core can be configured to contain both the inlet and outlet manifolds, in addition to the individual passages, and the entire core totally encapsulated by the grown IR window material, so that the inlet and outlet passageways can be later drilled from the window exterior into the inlet and outlet manifolds (from either the top, bottom, or edges) to allow the etching solution to remove the core through these inlets and outlets that were created by drilling. We have also found that the window can be machined and/or the core removed by chemical dissolution either before or after the machining and/or hydrostatic pressing operations.

One currently contemplated method to form the material around a selectively removable core is shown in FIGS. 7(a)-(d) and designated generally by the numeral 7000. In this embodiment, a group II/VI material 7100 is grown by CVD to a desired thickness. If a very thick layer is grown and "alligator skin" effect of large surface moieties 7101 form (a), then they must be polished to obtain a flat surface. Stopping CVD growth, followed by polishing and then continuing CVD growth was previously demonstrated by Purohit et. al. when growing ZnS on CVD-grown ZnSe. [Purohit, Kirsch and MacDonald; *Method for preparing laminates of ZnSe and ZnS*. 1990]. In addition, gas or solution phase chemical treatment may be employed to functionalize the surface for continued, or a second, CVD growth step of the material. Prior to the second CVD growth step a core material 7202 is placed (supported or unsupported by a frame) atop the polished CVD grown substrate 7201. Then CVD growth is continued around the core to form a core-containing CVD blank 7301(c). The cores (only one being designated by numeral 7302) then can be removed by chemical etching or mechanical processing, leaving behind fluid flow passageways or channels (only one in (d) being designated by numeral 7402) in the CVD blank 7401 that may require additional polishing of the "alligator skin" moieties 7303 of the type also shown in FIG. 7c. Once the core is removed, the interior surfaces of the channels or passages can be treated to make them non-transparent to the sensed or monitored wavelengths, such as treating them for IR absorbance.

Another contemplated novel method for implementing our invention designated generally by numeral 8000 is to form the material around a selectively removable core and to potentially remove the need for polishing the moieties 7101 in FIG. 7. As shown in FIGS. 8 (a)-(e) the CVD starter blank is grown from a single crystal, atomically smooth, wafer 8201 with the core material 8202 already affixed to the wafer surface (a). After sufficient growth occurs, the core-contain-

ing CVD crystal 8304 (b) can be cleaved from the wafer 8301 to leave behind a core/host piece 8304 with a near-atomically smooth surface 8305 so that the piece can then be flipped (c) and CVD growth on the smooth side 8305 can continue without the need for mechanical polishing or treatment (d). After completion of growth, the core material 8302 can be removed as previously discussed and any moieties 8303 on the outer surface can be polished, leaving behind a CVD grown structure 8401 with open channels 8402 (e).

Yet another currently contemplated method is to begin with a slab of the ZnS (either multispectral or single crystal) or some other suitable window material as previously listed and discussed, and then optionally polished one or both surfaces. One or more fluid passage forming cores are then placed on the slab, and material is formed around the selectively removable core. In this embodiment, a group II/VI material is grown by CVD to a desired thickness around the core forming a complete window. As stated before, if a very thick layer is grown and "alligator skin" effect of large surface moieties form, then these moieties can be polished to obtain a flat surface. Once again, gas or solution phase chemical treatment may be employed to functionalize the slab surface for the CVD growth step of the material. While our currently preferred embodiment is to grow the same group II/VI material as the base slab material, the base material and the grown material could be different a group II/VI materials, and other methods to build up the material over the cores in addition to CVD can be used.

Another window material growth method could employ sintering host particles together to a poly- or single-crystalline structure as performed by Ravichandran et. al. [2: Ravichandran and Shi; Polycrystalline sintered nano-gran zinc sulfide ceramics for optical windows. (U.S. Pat. No. 8,803,088 B1)], by only hot isostatically pressing the particles around the core material and following similar removal procedures such as mechanical force or selective chemical etching.

Other variations in the method of adding inlet and outlet manifolds can be employed either external or internal to the window. In the case of materials such as ms-ZnS, the hot isostatic pressing can be performed after the window, with its internal passages, has been created and before or after the core is removed by etching or other known techniques. The surface finish of the core can be adjusted to the desired surface finish inside the passages after the core is removed. The inside surfaces of the passages can utilize any non-transparent or absorbing coating, and one way to deposit this coating on the interior surfaces of the passages is by flowing a carrier liquid (with the optical coating in solution) through the passages, then evaporating the carrier liquid, with or without the addition of heat, to leave the optical coating bonded to the interior surfaces of the coolant passages. Inlet flow restrictions in the window can also be formed by the core by creating a core where the inlet section of the core has a reduced diameter so that, after core removal, a smaller inlet flow passageway has been created.

We have discovered that chemical vapor deposition (CVD) is one effective way of growing the ms-ZnS window with internal passages. The growth rate is 50-75 $\mu\text{m}/\text{h}$, making the fabrication method economically viable as well as technically feasible. One skilled in the art will now understand that, while the actively cooled window discussed here is an IR window that allows an IR sensor located behind the window to be protected from the very high environmental temperatures and aerodynamically induced thermal loads while flying at high speeds, this same window cooling

technology has other applications for both window heating or window cooling where a transparent window is exposed to high or low temperature environments or excessive heating or cooling loads. Of course, one skilled in the art will further understand that for heating loads, condensation rather than evaporation would be used to heat rather than cool the window. For example, the present invention is useable for windows for human-viewing or sensor-viewing from structures located in extreme environments, such as extraterrestrial planetary missions, spacecraft reentry sensors, specialty high temperature furnace sensor applications, high temperature geological investigations and the like.

While currently preferred embodiments of the invention have been illustrated and described, variations will be apparent to one skilled in the art without departing from the principles of the invention described herein. Therefore, we do not intend to be limited to the details shown and described above but intend to cover all such changes and modifications as are encompassed by the scope of the appended claims.

We claim:

1. A window system for a sensor, comprising:
 a monolithic material having a transmissivity to selected wavelengths of light to be monitored or sensed by the sensor;
 at least one passage arranged within the monolithic material; and
 a fluid in the at least one passage that renders the at least one passage optically non-transparent to the monitored or sensed light wavelengths.
2. The window system of claim 1, wherein the at least one passage is comprised of a plurality of passages configured as one of parallel-flow passages, series-flow passages, and a combination of parallel- and series-flow passages.
3. The window system of claim 1, wherein the material is selected to be transparent to the light wavelengths selected from at least one of long wavelength IR light, mid-wavelength IR light, short wavelength IR light, and visible light.
4. The window system of claim 1, wherein the material is one of multi-spectral zinc sulfide, single crystal zinc sulfide, zinc selenide, germanium, gallium arsenide, cadmium telluride, diamond, float zone silicone, or gallium phosphide.
5. A window system for a sensor, comprising:
 a monolithic material having a transmissivity to selected wavelengths of light to be monitored or sensed by the sensor;

- at least one passage arranged within the monolithic material; and
 an optically non-transparent to the monitored or sensed light wavelengths fluid in the at least one passage.
6. The window system of claim 5, wherein the at least one passage is comprised of a plurality of passages configured as one of parallel-flow passages, series-flow passages, and a combination of parallel- and series-flow passages.
7. The window system of claim 5, wherein the material is selected to be transparent to the light wavelengths selected from at least one of long wavelength IR light, mid-wavelength IR light, short wavelength IR light, and visible light.
8. The window system of claim 5, wherein the material is one of multi-spectral zinc sulfide, single crystal zinc sulfide, zinc selenide, germanium, gallium arsenide, cadmium telluride, diamond, float zone silicone, or gallium phosphide.
9. A window system for a sensor, comprising:
 a monolithic material having a transmissivity to selected wavelengths of light to be monitored or sensed by the sensor;
 at least one passage arranged within the monolithic material; and
 a fluid in the at least one passage, wherein the fluid hinders the selected wavelengths of light to be monitored or sensed by the sensor passing through the at least one passage.
10. The window system of claim 9, wherein the fluid in the at least one passage that is hindering the selected wavelengths of light to be monitored or sensed by the sensor passing through the at least one passage is opaque to the selected wavelengths of light to be monitored or sensed by the sensor.
11. The window system of claim 9, wherein the at least one passage is comprised of a plurality of passages configured as one of parallel-flow passages, series-flow passages, and a combination of parallel- and series-flow passages.
12. The window system of claim 9, wherein the material is selected to be transparent to the light wavelengths selected from at least one of long wavelength IR light, mid-wavelength IR light, short wavelength IR light, and visible light.
13. The window system of claim 9, wherein the material is one of multi-spectral zinc sulfide, single crystal zinc sulfide, zinc selenide, germanium, gallium arsenide, cadmium telluride, diamond, float zone silicone, or gallium phosphide.

* * * * *