



US010731735B1

(12) **United States Patent**  
**Wagner**

(10) **Patent No.:** **US 10,731,735 B1**  
(45) **Date of Patent:** **Aug. 4, 2020**

(54) **POWER TRANSFER SYSTEM AND METHOD USING A VARIABLE SPEED RATIO REGULATING DEVICE**

(56) **References Cited**

U.S. PATENT DOCUMENTS

- (71) Applicant: **Mainstream Engineering Corporation**, Rockledge, FL (US)
- (72) Inventor: **Jerald G. Wagner**, Myakka City, FL (US)
- (73) Assignee: **Mainstream Engineering Corporation**, Rockledge, FL (US)
- (\* ) Notice: Subject to any disclaimer, the term of this patent is extended or adjusted under 35 U.S.C. 154(b) by 108 days.

3,966,367	A *	6/1976	Erickson	.....	F04C 2/101	418/58
4,322,988	A *	4/1982	Hill	.....	F16H 3/722	192/61
6,195,990	B1 *	3/2001	Machesney	.....	F04C 2/103	123/41.12
6,688,851	B2	2/2004	Phaelan et al.	.....		
7,637,832	B1 *	12/2009	Laskowski	.....	F16H 3/722	475/31
7,686,724	B2 *	3/2010	Capito	.....	F16D 31/04	475/93
2005/0054469	A1 *	3/2005	Dyck	.....	B62D 11/18	475/85

(Continued)

(21) Appl. No.: **15/924,776**

FOREIGN PATENT DOCUMENTS

(22) Filed: **Mar. 19, 2018**

EP	0216540	A1 *	4/1987	.....	F16D 31/04
JP	2002250411	A *	9/2002	.....	F16D 31/02

- (51) **Int. Cl.**  
*F16H 3/72* (2006.01)  
*F04C 2/10* (2006.01)  
*F04C 14/06* (2006.01)  
*F04C 14/26* (2006.01)  
*F16H 48/06* (2006.01)  
*F04C 13/00* (2006.01)  
*F16H 48/27* (2012.01)  
*F16H 48/40* (2012.01)  
*F16D 43/284* (2006.01)

*Primary Examiner* — Tisha D Lewis  
(74) *Attorney, Agent, or Firm* — Michael W. O'Neill, Esq.

- (52) **U.S. Cl.**  
CPC ..... *F16H 3/722* (2013.01); *F04C 2/105* (2013.01); *F04C 14/06* (2013.01); *F04C 14/265* (2013.01); *F16H 48/06* (2013.01); *F04C 13/001* (2013.01); *F16D 43/284* (2013.01); *F16H 48/27* (2013.01); *F16H 48/40* (2013.01)

(57) **ABSTRACT**

A device is described for transmitting mechanical power that allows variable output-speed to input-speed ratios. Gear sets such as epicyclic gear sets have components that rotate about a common axis selectively at the same rotational speed and at different relative rotational speeds as determined by at least one of fluid flow and fluid pressure. One or more inlet ports and fluid passageways introduce a working fluid into one or more volume spaces between the components. The internal pressure and flow of the working fluid through the device is controlled to provide substantially infinite variability of the output-speed to input-speed ratios for applications where, for example, an engine provides the mechanical power for propelling a vehicle.

- (58) **Field of Classification Search**  
CPC ..... F16H 3/722; F04C 2/102; F04C 2/103  
See application file for complete search history.

**13 Claims, 13 Drawing Sheets**

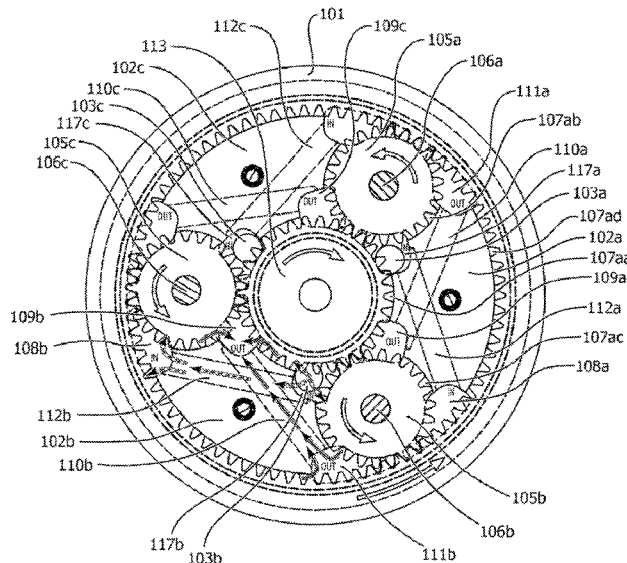

(56)

**References Cited**

U.S. PATENT DOCUMENTS

2011/0130236	A1*	6/2011	El-Zein .....	B60T 10/04 475/107
2012/0208667	A1*	8/2012	Lin .....	F04C 14/24 475/31

\* cited by examiner

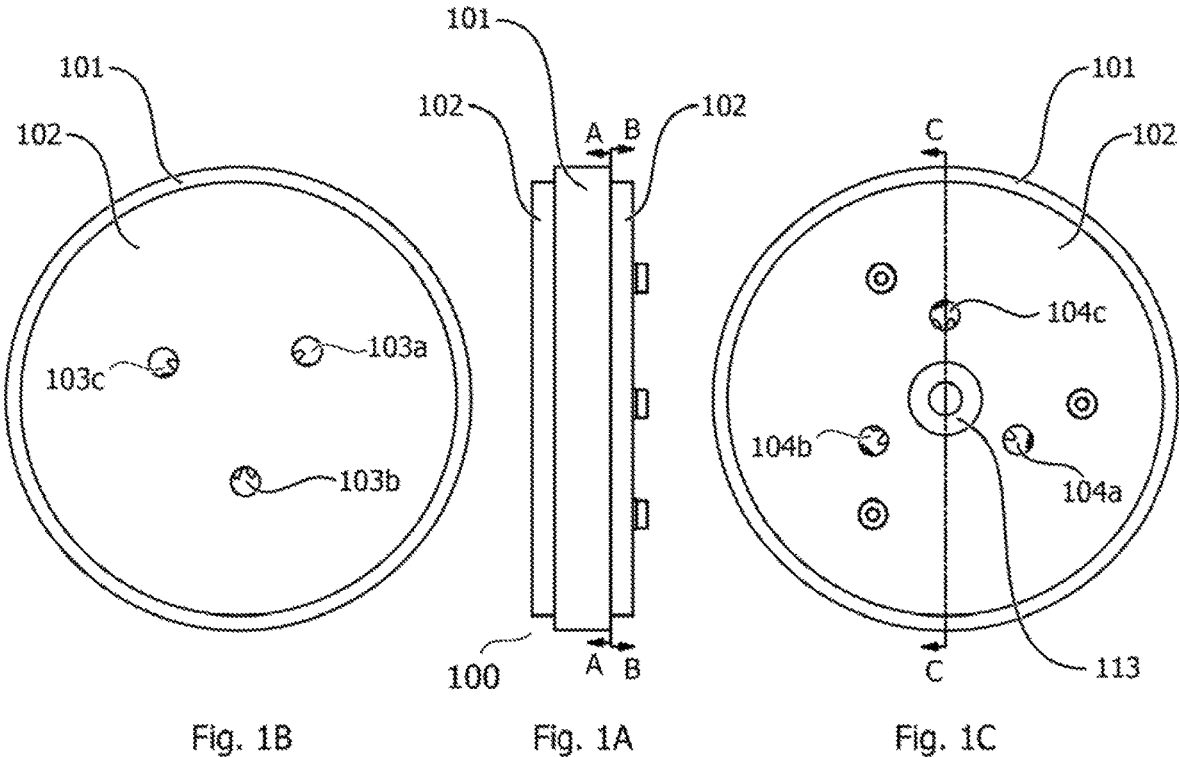

Fig. 1

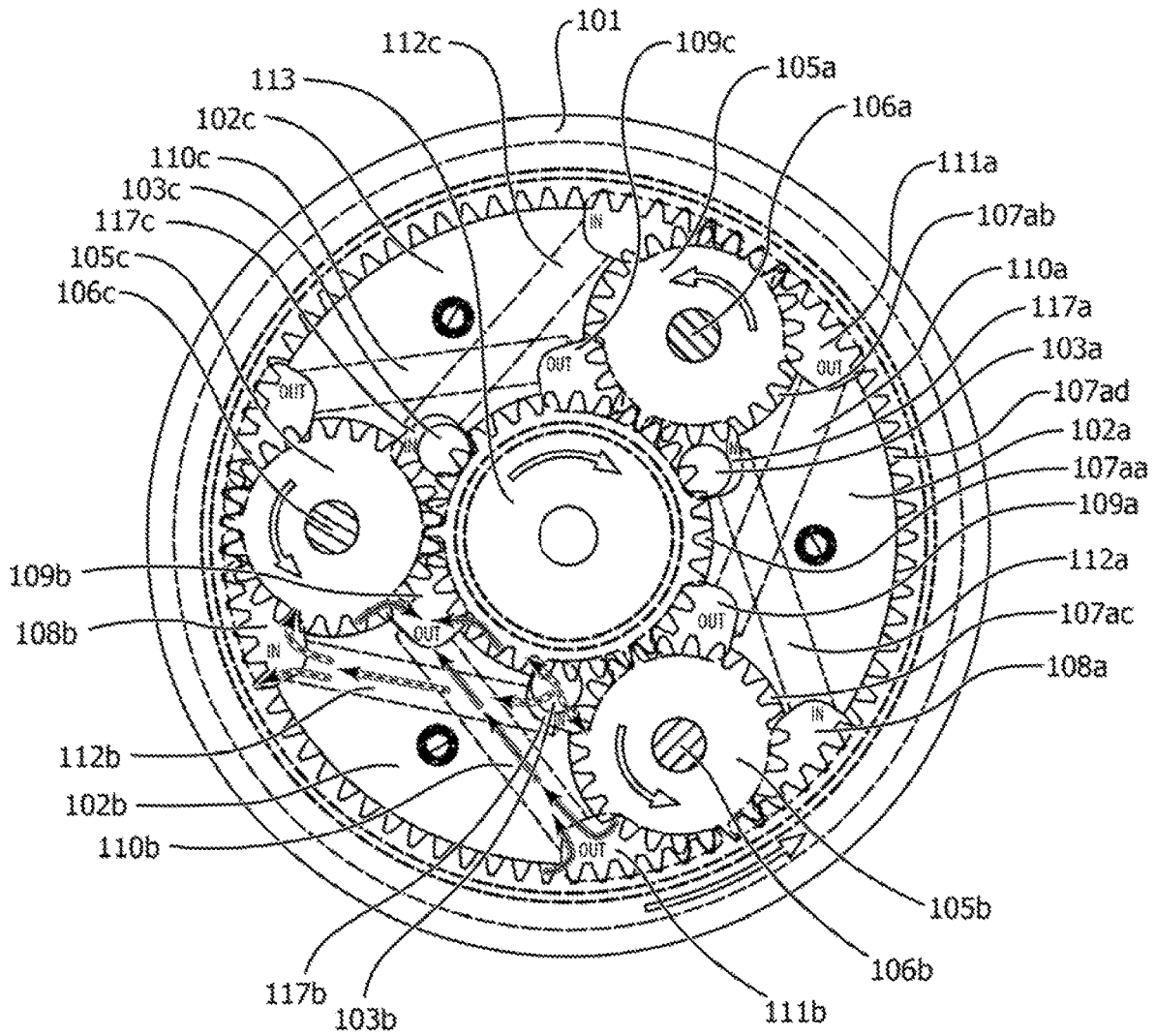

Fig. 2

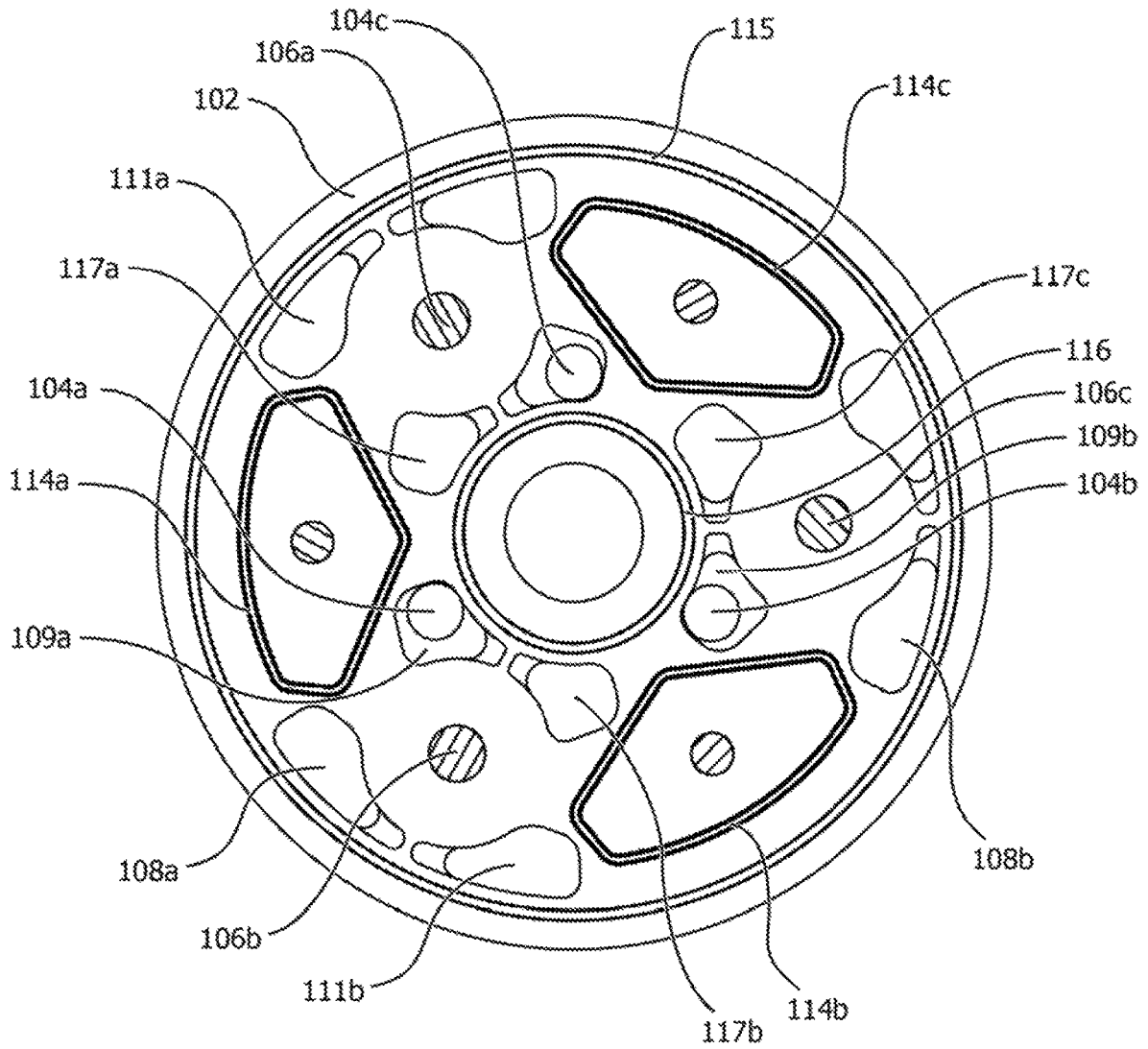

Fig. 3

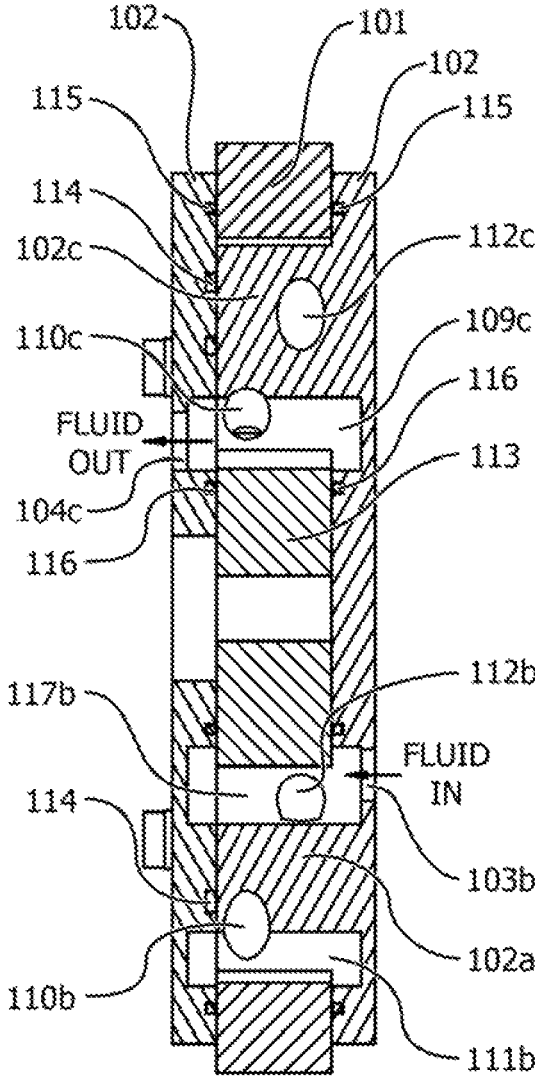

Fig. 4

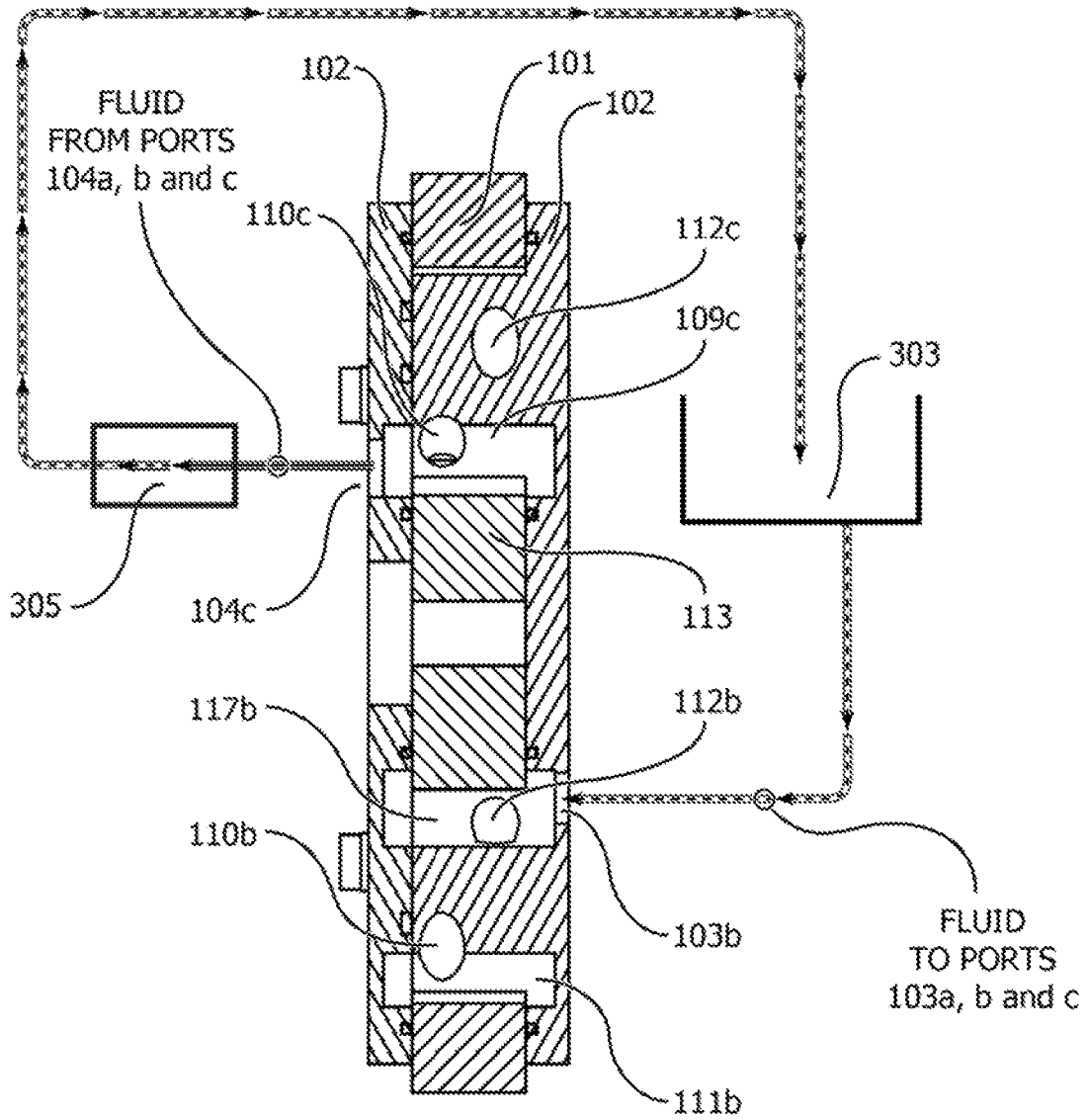

Fig. 5

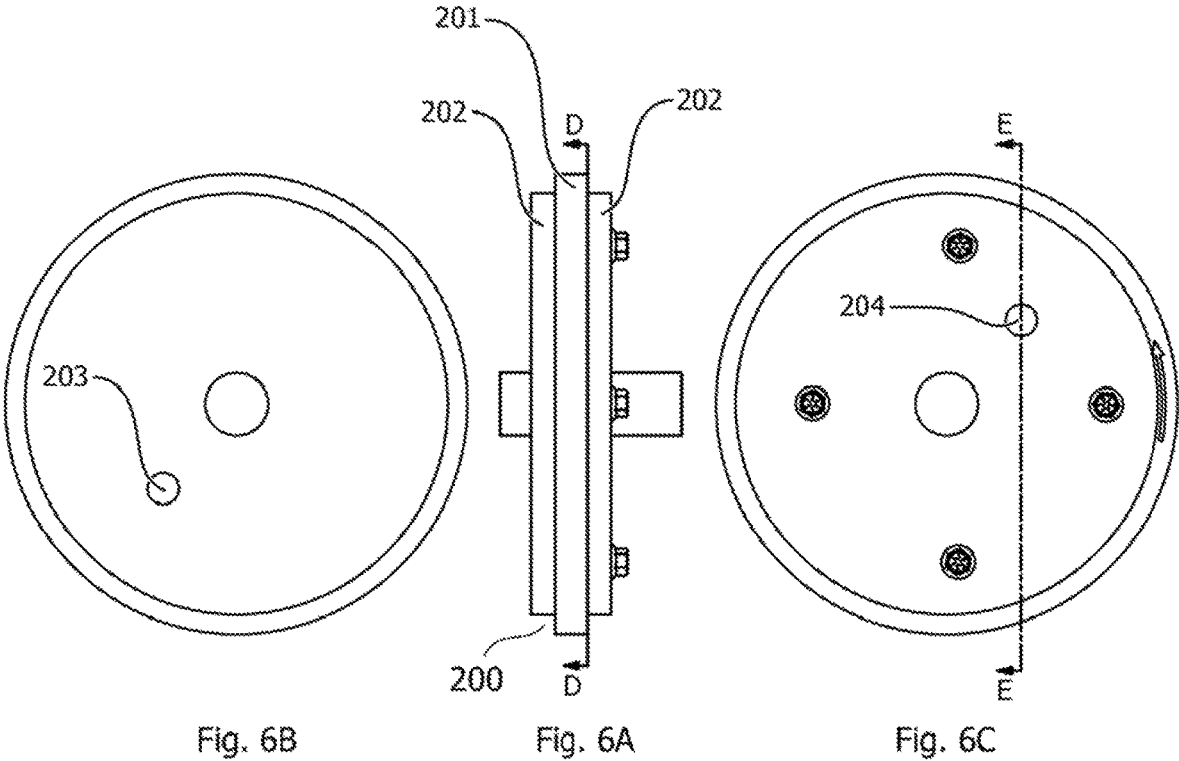

Fig. 6



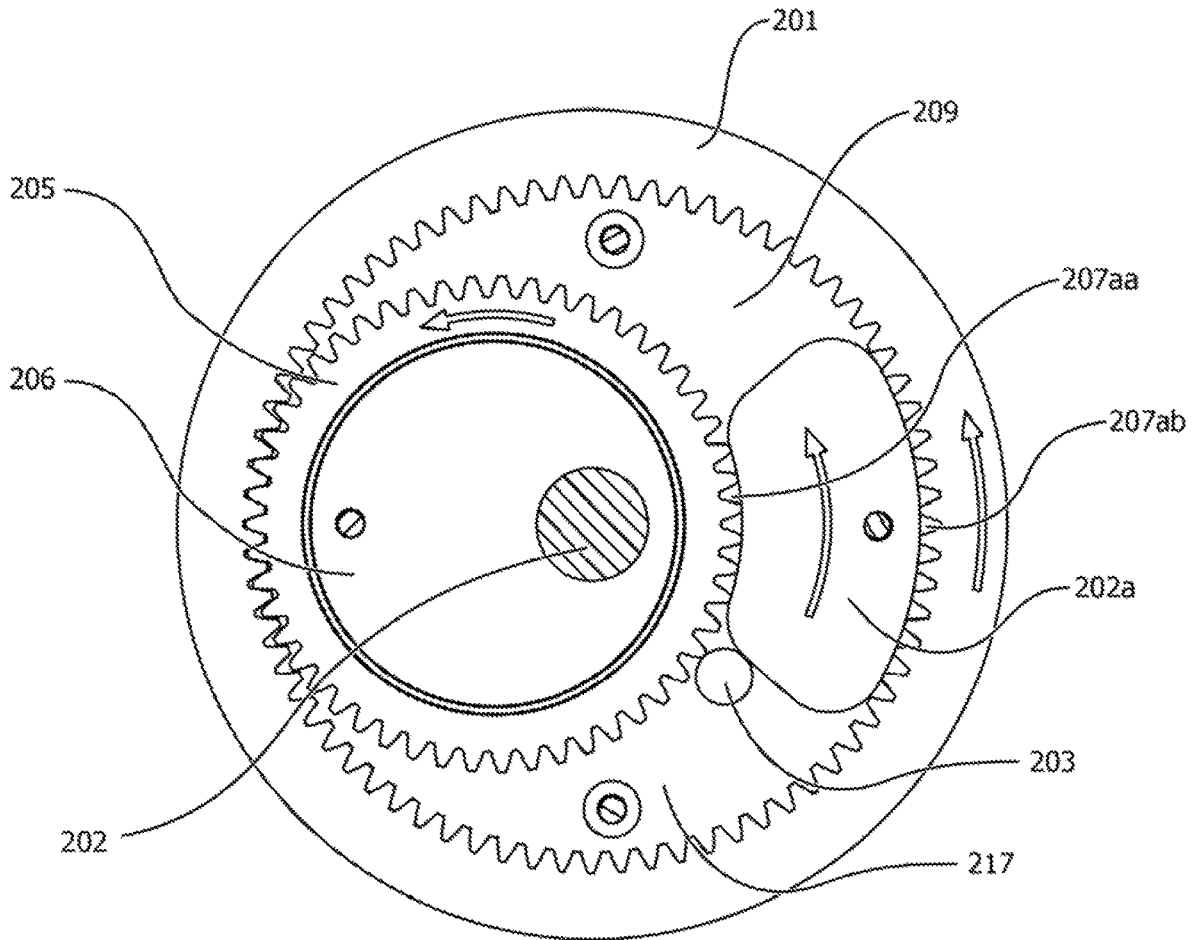

Fig. 7

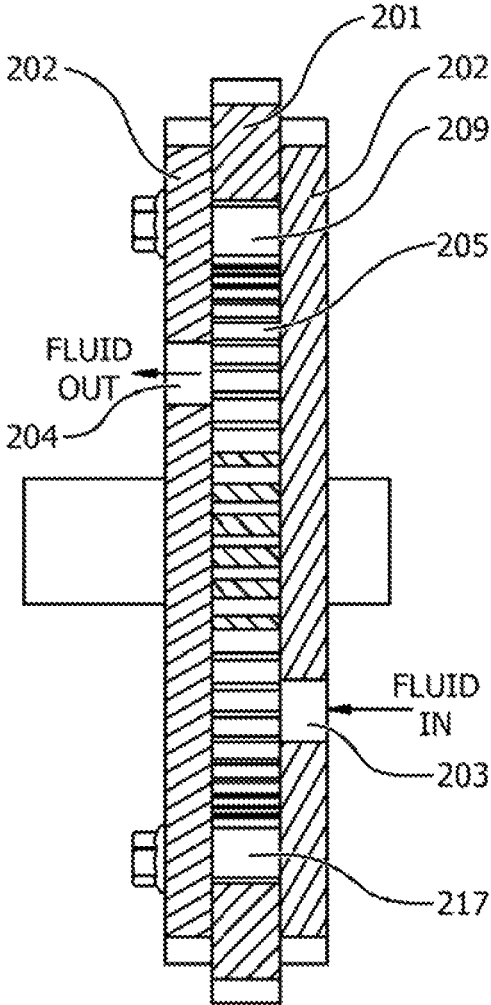

Fig. 8

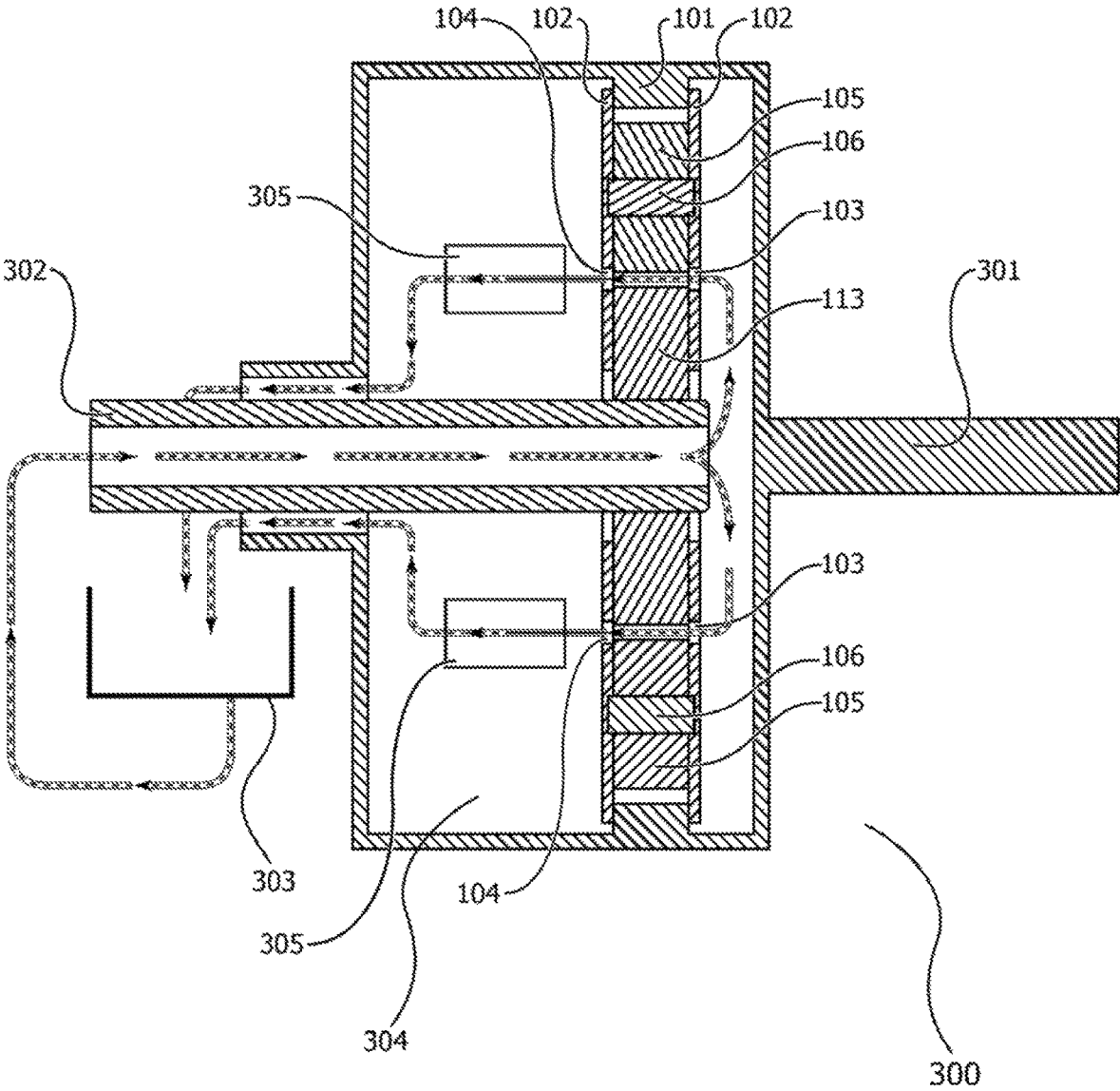
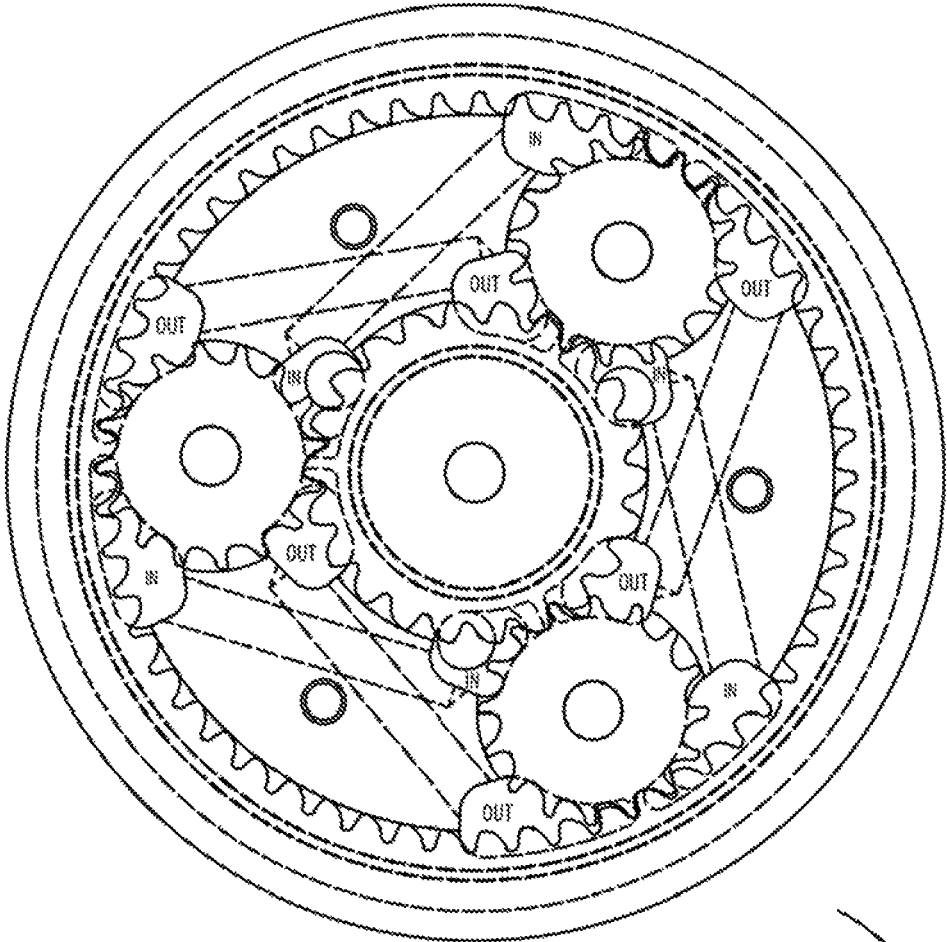

Fig. 9



400

Fig. 10

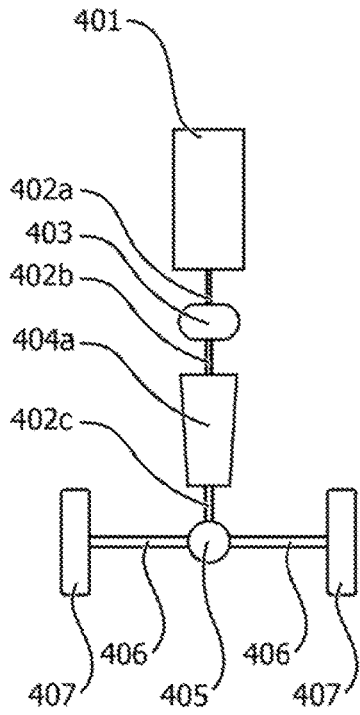

Fig. 11A

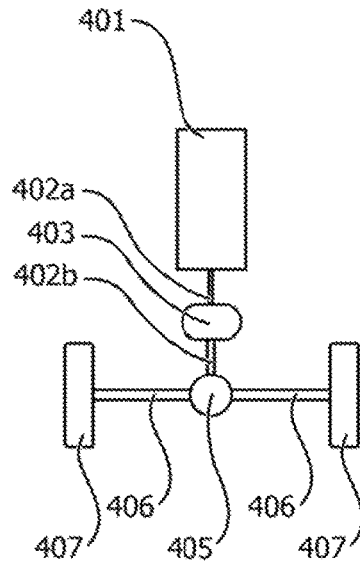

Fig. 11B

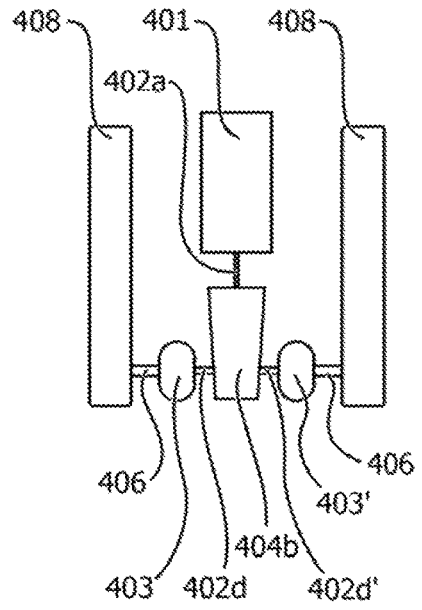

Fig. 11C

Fig. 11

Requirements			Torque Converter Performance			Regulating Device Performance		
Output Power (kW)	Output Speed (rpm)		Input Power (kW)	Input speed (rpm)	Engine Fuel Consumption (L/hr)	Input Power (kW)	Input speed (rpm)	Engine Fuel Consumption (L/hr)
35.0	185		176.7	1,831	47.14	38.4	723	12.2
67.7	370		176.8	1,834	47.18	70.5	1038	20.3
96.9	561		177.5	1,876	47.47	98.9	1155	27.8
120.6	760		178.3	1,903	48.07	122.0	1216	33.7
153.3	1,203		181.0	2,006	49.75	154.0	1495	41.2
164.0	1,723		181.4	2,155	50.72	164.0	1731	43.2

Fig. 13

Engine Performance Data			
Engine Speed (rpm)	Engine Power (kW)	BSFC (g/kW-hr)	Fuel Rate (L/hr)
2200	168	234.8	47.0
2100	168	233.5	46.8
2000	168	230.3	46.1
1900	168	226.1	45.3
1800	168	222.1	44.5
1700	166	220.1	43.6
1600	163	220.2	42.7
1500	157	220.6	41.4
1400	151	221.7	39.8
1300	136	222.9	36.6
1200	114	224.0	30.5
1000	74	223.2	19.7
500	30	224.0	8.0

Fig. 12

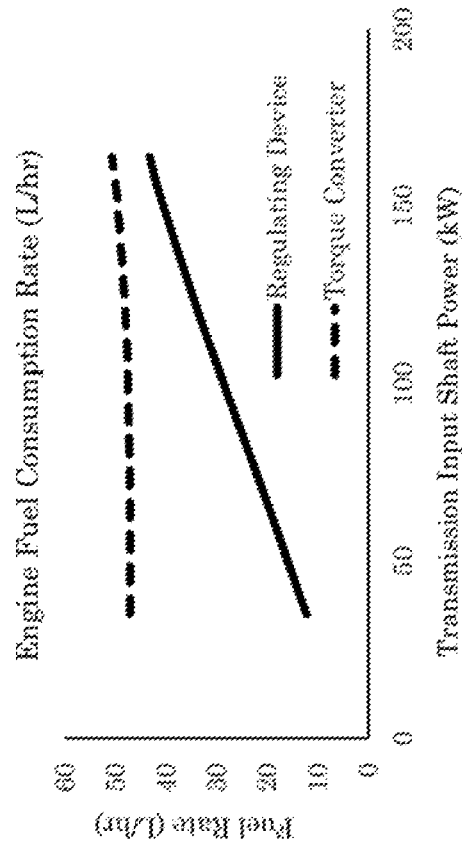

Fig. 15

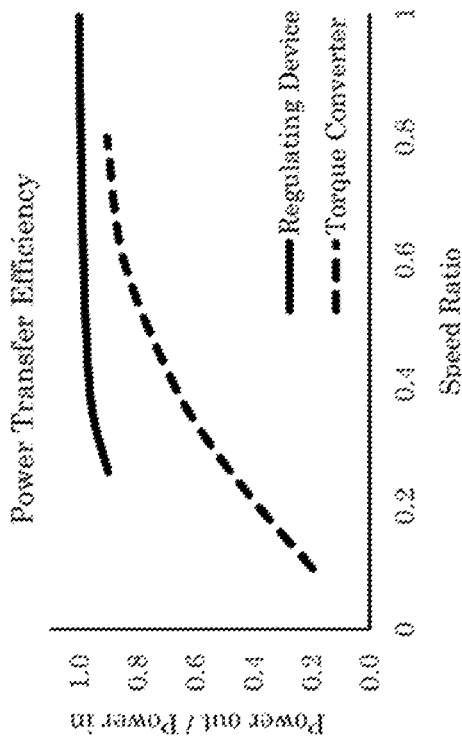

Fig. 14

**POWER TRANSFER SYSTEM AND METHOD  
USING A VARIABLE SPEED RATIO  
REGULATING DEVICE**

GOVERNMENT LICENSE RIGHTS

The U.S. Government has certain rights in this invention as provided by the terms of Contract Number: W56HZV-17-C-0172, Contract Title: Variable Speed Ratio Gear Drive System, awarded by the U.S. Army Tank Automotive Research Development and Engineering Center.

BACKGROUND AND SUMMARY OF THE  
INVENTION

The present invention relates to systems, such as a powertrain or a continuously variable transmission, that provide greatly improved speed control, torque transfer, fluid control, and lubrication by using an epicyclic gear set, a hypocycloid gear set and the like as a fluid pump and achieving infinitely variable control of the output shaft to input shaft rotational speeds (speed ratio) of the gear set by controlling fluid flow through, or pressure within, the fluid pump.

The use of a gear set like an epicyclic gear set to change output to input torque and speed ratios is common in many powertrains whose output and input shafts are on the same centerline because of compactness and a high torque capacity. Torque is transferred through the mechanical engagement of gear teeth. If a speed ratio change is desired, the gear set is engaged or disengaged, thereby generating a step change. Multiple gear sets have to be stacked to generate many small step changes between the minimum and maximum desired speed ratios at the expense of compactness.

I have recognized that an infinite speed ratio control between fully engaged and fully disengaged modes of gear sets like epicyclic and hypocycloid gear sets can be achieved by using the gear set as a fluid pump so that the speed ratio is controlled only by the internal pressure.

The present invention employs the novel principle that, if the relative rotational speed between any two of the three main rotating components (ring gear, planet carrier, and sun gear) of an epicyclic gear set is controlled, the overall speed ratio of the gear set can be controlled. The use of a fluid pump run by the gear set's rotating components is thus a simple and novel way to infinitely control the output shaft speed to input shaft speed ratio.

If, on one hand, the fluid is incompressible in a fluid pump and the pump's fluid flow outlet is closed, the pump is hydraulically locked. The pump drive gears then are prevented from having relative motion, and the entire gear set rotates as one unit, generating a 1:1 speed ratio. On the other hand, if the pump outlet is completely opened so that there is no fluid pressure, all gear set components are uncoupled so that no torque is transferred between the input and output, generating a speed ratio of 0. Fluid pressures between fully open and fully closed then control the gear set speed ratio. This has been shown using bulky external fluid pumps as disclosed, for example, in U.S. Pat. No. 6,688,851.

More advantageously, the present invention uses the mechanical power transfer gear set as the fluid pump to regulate its own speed ratio, thereby creating a very compact and self-contained infinitely variable power transfer device requiring very few components. The present invention provides the ability to engage a single gear set with infinite

variability between its minimum speed ratio (no fluid pressure) and maximum speed ratio (hydraulically locked).

BRIEF DESCRIPTION OF THE DRAWINGS

Other objects, advantages and novel features of the present invention will become apparent from the following detailed description when considered in conjunction with the accompanying drawings herein.

FIG. 1A-1C are, respectively, side, front end plate and rear end plate elevational views of an epicyclic gear set for implementing the present invention.

FIG. 2 is a cross-sectional view taken along line A-A of FIG. 1A.

FIG. 3 is a cross-sectional view taken along line B-B of FIG. 1A.

FIG. 4 is a cross-sectional view taken along line C-C of FIG. 1C.

FIG. 5 is a cross-sectional view similar to FIG. 4 but also schematically showing an external hydraulic system for speed ratio control.

FIG. 6A-6C are, respectively, side, front face and rear face elevational views of a hypocycloid gear set for implementing the present invention.

FIG. 7 is a cross-sectional view taken along line D-D of FIG. 6A.

FIG. 8 is a cross-sectional view taken along line E-E of FIG. 6C.

FIG. 9 is a cross-sectional view of one embodiment of the present invention utilized in a transmission system.

FIG. 10 is a cross-sectional view taken along line A-A of FIG. 1 where gear teeth of the type used in the embodiments of FIG. 1A-FIG. 1C and FIG. 6A-FIG. 6C are replaced with an alternative shape.

FIG. 11A-FIG. 11C are schematic plan views of three embodiments of the present invention used in power vehicles.

FIG. 12 is a table showing the output speed, power, and fuel consumption rate information for a common diesel engine.

FIG. 13 is a table showing the required output power and speed of one vehicle's powertrain system. The required input power and speed from the engine required at the input shaft of a torque converter system, and a system using this invention, are tabulated. Fuel consumption rates from FIG. 12 are applied for both systems.

FIG. 14 is a graph comparing output shaft to input shaft power transfer efficiencies of a torque converter and the present invention tabulated in FIG. 13.

FIG. 15 is a graph comparing the fuel consumption rates tabulated in FIG. 13.

DETAILED DESCRIPTION OF THE DRAWINGS

Referring now to FIG. 1A-1C showing side and opposed end views of an epicyclic gear set embodiment designated generally by numeral 100, a ring gear 101 and planetary carrier 102 have a seal for sealing fluid between the components which operate at different speeds rotating about the same centerline. Fluid enters the epicyclic gear set 100 through ports 103a, 103b, 103c shown in FIGS. 1A and 2 and exits through ports 104a, 104b, 104c shown in FIGS. 1C and 3.

Referring now to FIG. 2, a positive displacement pump is shown inside the ring gear 101. Assume for example that ring gear 101 is the input and a sun gear 113 is the output. The ring gear 101 engages with planet gears 105a, 105b and



**105e** which, in turn, engage with the sun gear **113**. Pinion axles **106a**, **106b** and **106c** are attached to the common planet carrier **102** which rotates about the same centerline as the ring gear **101** and the sun gear **113**. If the ring gear **101** is rotated counterclockwise, the planet gears **105a-105c** and the planetary carrier **102** rotate counterclockwise.

For implementing the present invention, pump bodies **102a**, **102b**, **102c** are located on the planetary carrier **102** between, respectively, the planet gears **105a** and **105b**, **105b** and **105c**, and **105e** and **105a**, as well as between the ring gear **101**, the sun gear **113**, and the end plates of the planetary carrier **102** to concurrently capture fluid in four gear teeth cavities per pump body **102a**, **102b**, **102c** which creates one positive displacement fluid pump section. For pump body **102a**, for example, the fluid enters through the port **103a** to be captured in gear teeth cavities at locations **107aa**, **107ab**, **107ac**, and **107ad** to create a pump section. One pump section can exist between every adjacent set of planet gears **105a-105c**. For example, pump body **102a** creates a pump section residing between the planet gears **105**, **105b**.

The pump section created by the pump body **102a**, the sun gear **113**, the ring gear **101**, and the planet gears **105a**, **105b** draws fluid in through port **103a**, filling a plenum **117a** and directly supplying the fluid to the gear teeth cavities **107a**, **107ab**. The fluid is supplied to the cavities **107ac** and **107ad** from plenum **117a** through the low-pressure transfer passage **112a** and a plenum **108a**. Due to the relative motion of the rotating gears, the supplied fluid becomes captured in the cavities **107aa**, **107ab**, **107ac**, **107ad** and is transported by gear rotation. The cavities **107ab**, **107ad** discharge the fluid to a plenum **111a**, then through the high-pressure transfer passage **110a** to a plenum **109a** where discharge fluid from the cavities **107aa**, **107ac** merge. The pump section's fluid exits the plenum **109a** through the port **104a** shown in FIG. 3.

Additional features for minimizing fluid leakage are also shown in FIG. 3. More specifically, a stationary seal **114a-114c** is provided for each pump section and rotates with the planetary carrier **102** to reduce leakage within the pump **100**. A sealing device **115** of conventional material and construction provides a seal between the planetary carrier **102** and the ring gear **101**, and a conventional sealing device **116** provides a seal between the planetary carrier **102** and the sun gear **113**.

FIG. 4 shows that the high-pressure transfer passage **110b**, and the low-pressure transfer passage **112b** of the pump section **102b**, and transfer passages **110c**, **112c** of the pump section **102c** are spaced apart axially (or on different levels) so as not to interconnect. A representative hydraulic control system for effecting speed ratio control is shown schematically in FIG. 5. Fluid enters through the ports **103a-103c** from a source such as a reservoir **303**. A regulating device **305** acting on the fluid exiting through the ports **104a-104c** alters fluid pressures in each pump section and therefore the sun gear **113**-to-ring gear **101** speed ratio.

Referring now to FIG. 6A-6C, a hypocyclic gear set embodiment of the present invention designated generally by numeral **200** is shown. A ring gear **201** and a carrier **202** which operate at different speeds rotate about the same axis and have a conventional sealing device for sealing fluid therebetween. Fluid enters the hypocyclic gear set **200** through a port **203** and exits through a port **204**.

FIG. 7 shows the positive displacement pump in the ring gear **201**. Assume, again by way of example, the ring gear **201** to be the input and the carrier **202** to be the output. The ring gear **201** engages with the carrier gear **205** which rotates

on a carrier pin **206** that is attached to the carrier **202** and has the same rotational axis as the ring gear **201**. When the ring gear **201** is rotated counterclockwise, the carrier gear **205** as well as the carrier **202** rotate counterclockwise. The carrier **202** has a pump body **202a** located between the carrier gear **205**, the ring gear **201**, and the end plates of the carrier **202** to concurrently capture fluid in gear teeth cavities at two locations **207aa**, **207ab** to create one positive displacement fluid pump section.

Fluid entering through the port **203** fills a plenum **217** and supplies gear teeth cavities **207aa**, **207ab**. Due to the relative motion of the rotating gears, the fluid becomes captured in the cavities **207aa**, **207ab** and is transported by gear rotation. The cavities **207aa**, **207ab** discharge the fluid to a plenum **209**, and the fluid then exits through the port **204** shown in FIGS. 6C and 8. A simple hydraulic control system similar to the epicyclic variant shown schematically in FIG. 5 can also be applied to the hypocyclic gear set embodiment for controlling fluid pressure.

Now referring to FIG. 9, a transmission system or the like designated by the numeral **300** has a rotating input shaft **301** that is an extension of ring gear **101** shown in FIG. 1A-1C and FIG. 2 which transfers torque to the sun gear **113** that is directly attached to the output shaft **302**. Both the input and output shafts **301**, **302** rotate in the same direction. Now output shaft speed can be varied from zero rpm up to the input shaft speed simply by controlling fluid pressure. Pumped fluid starts in a reservoir **303**, is pulled through the center of the output shaft **302** to enter the gear set at port **103**. Fluid pressure increases within the gear set, and the fluid exits at a higher pressure through the port **104** where it enters a regulator system **305** like that shown in FIG. 5 to control the output shaft-to-input shaft speed ratio, then it discharges into a cavity **304** rotating in unison with the ring gear **101**. Fluid exits the rotating cavity **304** coaxially about the input shaft **301** and enters the reservoir **303**.

The principles of the present invention are, however, not limited to epicyclic or hypocyclic gear sets and be applied to any similar operating devices. It is also not limited to gears only, but may be used with any meshing shape that creates a mechanical load path between the input and output rotating devices where voids in the rotating mechanisms of the mechanical load path are captured so as to create a positive displacement fluid pump. One example of an alternate embodiment designated generally by numeral **400** employing a meshing configuration different from that of the gears shown in the epicyclic arrangement of FIG. 2 and FIG. 3 but otherwise employing the same pump section construction is depicted in FIG. 10.

FIG. 11A-11C are illustrative examples of how the present invention can be employed in, for example, vehicle powertrains with the understanding that other uses will be apparent to one skilled in the art given the benefit of the present invention. In all three examples, similar parts are designated by the same numerals. An engine **401** rotates an output shaft **402a** that requires torque multiplication and speed control extending beyond the engine's range. Now referring to FIG. 11A, a shaft **402a** is the input to a regulating device **403** of the present invention of the types described above in connections with FIG. 1A through FIG. 10, where the device's output shaft **402b** is the input to a multi-range gearbox **404a** (here "gearbox" is intended to include any type of manual and automatic transmission) with an output shaft **402c** transferring power to a differentiating gearbox **405** that distributes power to drive axles **406** and tires **407**. In the embodiment of FIG. 11B, a shaft **402a** is the input to the regulating device **403** whose output shaft

5

**402b** directly transfers power to a differentiating gearbox **405** that distributes power to drive axles **406** and tires **407**. In the embodiment shown in FIG. **11C**, a vehicle rides on a continuous track or a series of wheels on each side of the vehicle **408**. A splitter-type gearbox **404b** and two regulating devices **403** together comprise a steering transmission. A shaft **402a** transfers power to the splitter type gearbox **404b** that has two output shafts **402d**, **402d'** that each transfer power to the respective device **403**, **403'**. Each device **403**, **403'** can be controlled independently to vary the speed to drive shafts **406** and continuous tracks or a series of wheels **408** for controlling vehicle direction.

## EXAMPLE

The regulating device of the present invention was used in a diesel engine-powered application as in FIG. **11A** to replace the torque converter in an automatic transmission and improve efficiency. FIG. **12** shows the diesel engine power and fuel consumption rates resulting from this application. FIG. **13** demonstrates the dramatic improvement in efficiency of the regulating device of the present invention compared to the torque converter at identical output shaft conditions because the former is more efficient and has the ability to control the speed ratio whereas the torque converter it replaced did not. Thereby, optimization of engine speed and power for similar overall output performance has been achieved with the present invention. Consequently, the engine speed at low speed ratios has been reduced to a region where the engine is more efficient combined with increased power transfer efficiency to provide a significant overall improvement. FIG. **14** graphically compares the efficiencies for my regulating device and a known torque converter and shows an optimized system using the former is significantly more efficient than the latter. FIG. **15** is a graph demonstrating that the engines fuel consumption rate is substantially improved when compared with the conventional torque converter system.

Therefore, I do not intend to be limited to the details shown and described in this application but rather seek to protect all such changes and modifications that are now apparent to those skilled in the art and that are encompassed by the scope of the appended claims.

I claim:

**1.** A device for transmitting mechanical power that allows variable output-speed to input-speed ratios, comprising: first, second, and third components operatively arranged to rotate about a common axis selectively at the same rotational speed and at different relative rotational speeds, as determined by at least one of fluid flow and fluid pressure, at least one inlet port and fluid passageway for introducing a working fluid into at least one volume space defined between at least one of the first and second components and of the second and third components, at least one outlet port, at least one fluid passageway configured and arranged to collect the working fluid exiting from the at least one volume space and to allow the collected working fluid to exit at the at least one outlet port, and an apparatus configured to control at least one of internal pressure and flow of the working fluid through the device, and where the volume space between the one or more of the first and second components and the one or more of the second and third components is a variable

6

volume when the working fluid is allowed to flow through the device and is a fixed volume when the fluid is prevented from flowing through the device.

**2.** The device according to claim **1**, wherein output speed provided from the device equals input speed to the device when the working fluid is prevented from flowing through the device.

**3.** The device according to claim **1**, wherein, when the working fluid is allowed to flow, an output speed provided by the device is a selected fraction of a device input speed that is controlled by varying the pressure of the working fluid.

**4.** The device according to claim **1**, wherein the first component is configured to function as a ring gear, the second component is configured to function as at least one planet gear, and the third component is configured to function as sun gear.

**5.** The device according to claim **4**, wherein input power is applied to rotate one of the ring gear and the sun gear and output power is provided by rotation of one of the sun gear and ring gear, respectively.

**6.** The device according to claim **4**, wherein the at least one volume space comprises variable volumes created by meshing of a portion of the ring gear with at least one of the planet gears and by meshing of at least one of the planet gears with a portion of the sun gear.

**7.** The device according to claim **6**, wherein interactions of the ring gear with the at least one planet gear and with the at least one planet gear with the sun gear transmit the mechanical power.

**8.** The device according to claim **6**, further comprising a hydraulic control system to control the fluid pressure of the working fluid that exits the variable volumes between the ring gear and the at least one planet gear and between the at least one planet gear and the sun gear controls relative rotational speeds between the ring gear and the sun gear.

**9.** The device according to claim **8**, wherein the at least one input port and at least one fluid passageway are configured to allow the working fluid entering the device to be distributed to an inlet portion of the meshing portions and the at least one outlet port and at least one fluid passageway to allow the working fluid that exits the variable volumes to flow to the at least one outlet port.

**10.** The device according to claim **1**, wherein an engine provides the mechanical power that is used to propel a vehicle.

**11.** The device according to claim **10**, wherein the device is one of a manual and automatic transmission directly to drive axles of the vehicle or indirectly through a differentiating gearbox.

**12.** The device according to claim **10**, wherein the vehicle comprises one of continuous tracks and skid-steer wheel system with wheels on one side of the vehicle moving in unison and wheels on another side of the vehicle moving in unison for vehicle movement, and the device is arranged between each side of a splitter gearbox and the continuous tracks or the skid-steer wheel system.

**13.** The device according to claim **1**, wherein the working fluids control apparatus is configured to provide a substantially infinitely variable output-speed to input-speed ratio.

\* \* \* \* \*